

# **PRACTICAL PHARMACEUTICAL ANALYTICAL TECHNIQUES**



**ASIF HUSAIN**

**DARSHAN PUBLISHERS**

# **PRACTICAL PHARMACEUTICAL ANALYTICAL TECHNIQUES**

## **Authored by**

### **Dr. Asif Husain**

Sr. Assistant Professor,  
Department of Pharmaceutical Chemistry  
Faculty of Pharmacy,  
Hamdard University (Jamia Hamdard)  
New Delhi-110062,  
India

## **Published By**

### **Darshan Publishers,**

Kakkaveri, Rasipuram,  
Namakkal, Tamil Nadu,  
India – 637406.

[www.darshanpublishers.com](http://www.darshanpublishers.com)

e-mail:[darshanpublishers12@gmail.com](mailto:darshanpublishers12@gmail.com)

First published in India in 2015

This edition published by Darshan publishers  
<http://www.darshanpublishers.com>

©2015 Dr Asif Husain. All rights reserved.

Apart from any use permitted under Indian copyright law, this publication may only be reproduced, stored or transmitted, in any form, or by any means with prior permission in writing of the publishers or in the case of reprographic production in accordance with the terms of licenses issued by the Copyright Licensing Agency.

Copy Right policy is to use papers that are natural, renewable and recyclable products and made from wood grown in sustainable forests. The logging and manufacturing processes are expected to conform to the environmental regulations of the country of origin. Whilst the advice and information in this book are believed to be true and accurate at the date of going to press, neither the authors nor the publisher can accept any legal responsibility or liability for any errors or omissions that may be made. In particular, (but without limiting the generality of the preceding disclaimer) every effort has been made to check quantity of chemicals; however it is still possible that errors have been missed.

**ISBN: 978-81-931973-1-8**

**Price: Rs: 300/-**

**Printed by: Sri Balaji offset, Rasipuram, Namakkal, Tamil Nadu, India**

## PREFACE

Practical Pharmaceutical Analytical Techniques book is meant for undergraduate and postgraduate pharmacy and science students. Chemistry is a fascinating branch of science. Practical aspects of chemistry are interesting due to colour reactions, synthesis of drugs, analysis and observation of beautiful crystal development. The important aspects involved in the practicals of pharmaceutical analytical chemistry have been comprehensively covered in the book. I hope the students studying practical aspects of pharmaceutical analysis would be benefitted from this book.

In the book, different pharmaceutical analytical techniques (PAT) have discussed with their applications followed by general and specific safety notes in detail. Explanation of some common laboratory processes are given followed by a number of equipments, apparatuses and glass wares used in a pharmaceutical analytical chemistry lab. Limit tests with explanation have been given. Basic concepts related to spectroscopic and chromatographic techniques are discussed. Procedure to calibrate a UV spectrometer is provided with concept. Preparation of calibration curve followed by assay method for analysis of ciprofloxacin, metformin, and rifampicin are explained. Interpretation of IR spectra of ethanol, acetone, formaldehyde and aspirin has been explained in simple language. The working of HPLC instrument is given with its parts. Paracetamol's assay by HPLC is discussed. TLC experiments of amino acid, food dye pigments, and an OTC drug are also furnished. Preparation of commonly used reagents has also been given.

I hope that this book will cater to the needs of the B. Pharm, M.Pharm and M.Sc. students during their study as well as after completion of their course. Constructive comments on the content and approach of the book from the readers will be highly appreciated. My email address is drasifhusain@yahoo.com.

Dr. Asif Husain  
New Delhi

## ABOUT THE AUTHOR



**Dr. Asif Husain** is Senior Assistant Professor at the Faculty of Pharmacy, Jamia Hamdard (Hamdard University), New Delhi. He received his M.Pharm. and Ph.D. degrees in 1996 and 2000, respectively, from Hamdard University, New Delhi and has been involved in teaching and research for more than 15 years. He has more than 175 peer-reviewed research publications to his credit. Dr. Husain has attended several national and international conferences in India and abroad including USA. He is a recipient of several awards and honors including a visiting fellowship from Youngstown State University, Ohio, USA, and his research has been funded by UGC, AICTE, DST and AYUSH. He has collaboration with different research organizations like National Institute of Health (NIH), National Cancer Institute (NCI), The National Institute of Allergy and Infectious Diseases (NIAID), USA, etc. He has guided a number of M. Pharm/Ph.D. students and authored several books in the field of pharmacy.

## **ACKNOWLEDGEMENT**

“Teacheth man that which he knew not” (Al-Quran)

First of all, I bow in reverence of Almighty Allah, the creator of this universe.

I would like to express my deep sense of gratitude to my parents- my Ammi (mother) Hajjan Shahjahan Begum and my father (Papa) Haji Rafiq Husain sahib, for their constant encouragement, help, love, moral support and prayers. I am highly indebted to my beloved son Ayaan for continuous moral support and keeping my spirits high.

Special thanks and love to my brother Aftab for his help, encouragement and respect. Love showered upon me by Mysha, Arhaan and Arshaan is priceless.

It gives me great pleasure to extend my respect and profound gratitude to my mentor, Late Prof. M.S.Y. Khan Sir, Jamia Hamdard for his help, guidance, motivation and everlasting inspirations.

I am highly thankful to my friend Dr Mohammad Shaharyar for his valuable suggestions, help and support. Sincere thanks are also due to my colleagues Dr M. Mumtaz Alam and Dr. M. S. Zaman for their support and help.

Special thanks are due to my student Mohd Arif who has put in great efforts in materializing this work through his inputs. I am thankful to my students Farah Iram and Md Azhar Iqbal for their help in this endeavour.

I am also thankful to Dr. T. Sivakumar (Managing Director) of Darshan Publishers for taking keen interest in publishing this book.

**ASIF HUSAIN**

## CONTENTS

<b>S. No</b>	<b>Chapters</b>	<b>Pages</b>
<b>i</b>	Preface	<b>i</b>
<b>ii</b>	About the author	<b>ii</b>
<b>iii</b>	Acknowledgements	<b>iii</b>
<b>1</b>	Introduction	<b>1</b>
<b>2</b>	Pharmaceutical analytical techniques (PAT)	<b>4</b>
<b>3.</b>	Safety notes	<b>19</b>
<b>4.</b>	Common laboratory processes	<b>21</b>
<b>5.</b>	Common laboratory apparatuses	<b>28</b>
<b>6.</b>	Limit tests	<b>30</b>
<b>7.</b>	Basic concepts of spectroscopic and chromatographic techniques	<b>42</b>
<b>8.</b>	Calibration of UV Spectrophotometer	<b>60</b>
<b>9.</b>	Preparation of calibration curve of ciprofloxacin	<b>64</b>
<b>10.</b>	Assay of ciprofloxacin capsule/tablet	<b>66</b>
<b>11.</b>	Preparation of calibration curve of metformin	<b>67</b>
<b>12.</b>	Assay of metformin tablet/capsule	<b>68</b>
<b>13.</b>	Assay of rifampicin tablet/capsule	<b>69</b>
<b>14.</b>	Interpretation of the IR spectra of ethanol, acetone and formaldehyde	<b>71</b>
<b>15.</b>	Interpretation of the IR spectra of aspirin	<b>73</b>
<b>16.</b>	Study the working of HPLC instrument	<b>75</b>
<b>17.</b>	Assay of paracetamol by HPLC.	<b>81</b>
<b>18.</b>	TLC of amino acids	<b>84</b>
<b>19.</b>	TLC of food dye pigments	<b>87</b>
<b>20.</b>	Analysis of a non-prescription medicine (OTC drug)	<b>89</b>
<b>21.</b>	Preparation of some common reagents	<b>91</b>
<b>22</b>	References	<b>107</b>

## 1. INTRODUCTION

The main aim of the pharmaceutical drugs is to serve the human to make them free from potential illness or prevention of the disease. For the medicine to serve its intended purpose they should be free from impurity or other interference which might harm humans. Here, analytical chemistry plays vital role in achieving the goal of betterment of human beings.

Chemistry is considered both basic and applied science. When teaching chemistry, teachers should emphasize both theories and experiments; chemistry experiments play an important role in teaching and serve as an ideal tool for combining theory and practice. Therefore, chemistry experiments should focus on learning goals and developing students' laboratory skills, scientific reasoning skills, knowledge about experimental design, and comprehensive ability. Instrumental analytical chemistry is a scientific field which includes a huge amount of different techniques. These techniques are widely used in different parts of the research, drug development, quality control, clinical diagnostics, structural analysis and many more.

Analytical chemistry is the study of the separation, identification, and quantification of the chemical components of natural and artificial materials. Qualitative analysis gives an indication of the identity of the chemical species in the sample, and quantitative analysis determines the amount of certain components in the substance. The separation of components is often performed prior to analysis.

There is an increased demand of analytical procedures during the drug research and development process, drug synthesis, drug therapy, in the analysis of the structure and concentration of different analytes in samples. Sophisticated procedures are required to detect the analyte as it can be found in very low concentrations in the samples. For the sake of this it is necessary the preparation of pure substances, the separation of the analytes of interest from the impurities or the possible elimination of the unnecessary matrix components. So nowadays the "instrumental" analysis involve not simply the



measurement itself, but also a complex process including sampling, sample preparation, measurement and evaluation of the results as well. The increasing quality claim on the market requires the analysis of a great number of samples in a short period of time. Thus, improving progress can be observed in reducing the volume of samples, in the development of high-through screening methods and in automation. In order to get accurate and reliable results, it is necessary to know the applied techniques as well as the information they provide, very well.

Analytical methods can be separated into classical and instrumental. Classical methods (also known as wet chemistry methods) use separations such as precipitation, extraction, and distillation and qualitative analysis by color, odor, or melting point. Classical quantitative analysis is achieved by measurement of weight or volume. Instrumental methods use an apparatus to measure physical quantities of the analyte such as light absorption, fluorescence, or conductivity. The separation of materials is accomplished using chromatography, electrophoresis or field flow fractionation methods.

Analytical chemistry is also focused on improvements in experimental design, chemometrics, and the creation of new measurement tools to provide better chemical information. Analytical chemistry has applications in forensics, bioanalysis, clinical analysis, environmental analysis, and materials analysis.

Pharmaceutical analysis simply means analysis of a pharmaceutical(s). It encompasses any examination of chemical material with the goal of eliciting information regarding its constituents: their character (form, quality, or pattern of chemical bonding), quantity (concentration, content), distribution (homogeneity, but also distribution with respect to internal and external boundary surfaces), and structure (spatial arrangement of atoms or molecules). This goal is pursued using an appropriate combination of chemical, physical, and biological methods. From a strategic standpoint the challenge is to solve the analytical problem in question as completely and reliably as possible with the available methods, and then to interpret the results correctly. Sometimes it becomes apparent that none of the methods at hand are in fact suitable, in which case it is the methods themselves that must be improved, perhaps the most important rationale for intensive

basic research directed toward the increased effectiveness of problem-oriented analysis in the future.

Modern analytical chemistry is dominated by instrumental analysis. Many analytical chemists focus on a single type of instrument. Academics tend to either focus on new applications and discoveries or on new methods of analysis. The discovery of a chemical present in blood that increases the risk of cancer would be a discovery that an analytical chemist might be involved in. An effort to develop a new method might involve the use of a tunable laser to increase the specificity and sensitivity of a spectrometric method. Many methods, once developed, are kept purposely static so that data can be compared over long periods of time. This is particularly true in industrial quality assurance (QA), forensic and environmental applications.

Analytical chemistry plays an increasingly important role in the pharmaceutical industry where, aside from QA, it is used in discovery of new drug candidates and in clinical applications where understanding the interactions between the drug and the patient are critical.

The pharmaceutical and chemical industries today are the source of relatively small fraction of the samples subject to analysis. Rocks, soils, water, air, and biological matrices, not to mention mankind itself and a wide array of drugs & consumer goods, together with raw materials and sources of energy constitute the broad spectrum of analytical samples in the modern era.

## **2. PHARMACEUTICAL ANALYTICAL TECHNIQUES (PAT)**

Modern analytical techniques have now become the soul of pharmaceutical sciences. All the branches in pharmacy need to have thorough knowledge about it and so it is the subject which is common to all the pharmacy disciplines. This subject basically involves study about instrumental analysis that includes UV-Visible spectroscopy, infrared spectroscopy, mass and chromatographic techniques, NMR spectroscopy, X-ray diffraction methods, optical rotatory dispersion techniques, thermal method of analysis, electrophoresis and radioimmunoassay techniques. Although modern pharmaceutical analytical chemistry is dominated by sophisticated instrumentation, the roots of analytical chemistry and some of the principles used in modern instruments are from traditional techniques many of which are still used today. These techniques also tend to form the backbone of most undergraduate analytical chemistry educational labs. There are two types of analysis- qualitative and quantitative.

A qualitative analysis determines the presence or absence of a particular compound, but not the mass or concentration. By definition, qualitative analyses do not measure quantity. There are numerous qualitative chemical tests, for example, the acid test for gold and the Kastle-Meyer test for the presence of blood. Inorganic qualitative analysis generally refers to a systematic scheme to confirm the presence of certain, usually aqueous, ions or elements by performing a series of reactions that eliminate ranges of possibilities and then confirms suspected ions with a confirming test. Sometimes small carbon containing ions are included in such schemes. With modern instrumentation these tests are rarely used but can be useful for educational purposes and in field work or other situations where accesses to state-of-the-art instruments are not available or expedient.

Quantitative analysis refers to determine the quantity or amount of a particular compound by applying analysis technique(s). There are several techniques for quantitative estimation of pharmaceutical agents; some of them are outlined in the following pages.

## GRAVIMETRIC ANALYSIS

Gravimetric analysis involves determining the amount of material present by weighing the sample before and/or after some transformation. A common example used in undergraduate education is the determination of the amount of water in a hydrate by heating the sample to remove the water such that the difference in weight is due to the loss of water.

## VOLUMETRIC ANALYSIS

Titration involves the addition of a reactant to a solution being analyzed until some equivalence point is reached. Often the amount of material in the solution being analyzed may be determined. Origin of the titrimetric method of analysis goes back to the middle of the 18th century. Gay-Lussac invented the volumetric method which subsequently leads to the origin of term titration. Although the assay method is very old yet there are signs of some modernization, i.e., spreading of non-aqueous titration method, expanding the field of application of titrimetric methods to very weak acids and bases as well as potentiometric end point detection improving the precision of the methods.

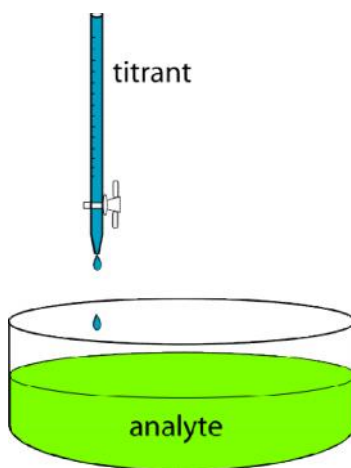

With the development of functional group analysis procedures, titrimetric methods have been shown to be beneficial in kinetic measurements which are in turn applied to establish reaction rates. There are many advantages associated with these methods which

include saving time and labor, high precision and the fact that there is no need of using reference standards. Most familiar to those who have taken chemistry during secondary education is the acid-base titration involving a color changing indicator. There are many other types of titrations, for example potentiometric titrations. These titrations may use different types of indicators to reach some equivalence point. In addition to its application in drug estimation, titrimetry is still used for the estimation of degradation products of some pharmaceuticals.

## **SPECTROSCOPIC TECHNIQUES**

Spectroscopy measures the interaction of the molecules with electromagnetic radiation. Spectroscopy consists of many different applications such as atomic absorption spectroscopy, atomic emission spectroscopy, ultraviolet-visible spectroscopy, X-ray, fluorescence spectroscopy, infrared spectroscopy, Raman spectroscopy, dual polarisation interferometry, nuclear magnetic resonance spectroscopy, Mass spectrometry, photoemission spectroscopy, Mössbauer spectroscopy and so on.

### **Spectrophotometry**

Spectrophotometry is a group of methods which find an important place in pharmacopoeias are spectrophotometric methods based on natural UV absorption and chemical reactions. Spectrophotometry is the quantitative measurement of the reflection or transmission properties of a material as a function of wavelength. The advantages of these methods are low time and labor consumption. The precision of these methods is also excellent. The use of UV–Vis spectrophotometry especially applied in the analysis of pharmaceutical dosage form has increased rapidly over the last few years. The colorimetric methods are usually based on complex-formation reaction, oxidation-reduction process, and catalytic effect. Colorimetric methods are regularly used for the assay of bulk materials. The colorimetric method is also exploited for the determination of cardiac glycosides.

Several approaches using spectrophotometry for determination of active pharmaceutical ingredients in bulk drug and formulations have been reported. Derivative spectroscopy uses first or upper derivatives of absorbance with respect to wavelength for qualitative investigation and estimation. The concept of derivatizing spectral data was first offered in the 1950s, when it was shown to have many advantages. However, the technique received little consideration primarily due to the complexity of generating derivative spectra using early UV–Visible spectrophotometers. The introduction of microcomputers in the late 1970s made it generally convincing to use mathematical methods to generate derivative spectra quickly, easily and reproducibly. This significantly increased the use of the derivative technique. The derivative method has found its applications not only in UV-spectrophotometry but also in infrared, atomic absorption, fluorescence spectrometry, and fluorimetry. The use of derivative spectrometry may be of advantage whenever quantitative study of normal spectra is problematic.

### **Near Infrared spectroscopy (NIRS)**

NIRS is a rapid and non-destructive procedure that provides multi component analysis of almost any matrix. Recently, NIR spectroscopy has gained a wide appreciation within the pharmaceutical industry for raw material testing, product quality control and process monitoring. The growing pharmaceutical interest in NIR spectroscopy is due to some major advantages over other analytical techniques, e.g. an easy sample preparation without any pretreatments, the probability of separating the sample measurement position by use of fiber optic probes, and the expectation of chemical and physical sample parameters from one single spectrum. NIRS in combination with multivariate data analysis opens many interesting perceptions in pharmaceutical analysis, both qualitatively and quantitatively.

### **Mass spectrometry (MS)**

Mass spectrometry measures mass-to-charge ratio of molecules using electric and magnetic fields. There are several ionization methods: electron impact, chemical

ionization, electrospray, fast atom bombardment, matrix assisted laser desorption ionization, and others. Also, mass spectrometry is categorized by approaches of mass analyzers: magnetic-sector, quadrupole mass analyzer, quadrupole ion trap, time-of-flight, Fourier transform ion cyclotron resonance, and so on. Among the main branches of contemporary analytical atomic spectrometry, the most widespread and universal are optical and mass spectrometry. In the direct elemental analysis of solid samples, the new leaders are laser-induced breakdown and laser ablation mass spectrometry, and the related techniques with transfer of the laser ablation products into inductively coupled plasma. Advances in design of diode lasers and optical parametric oscillators promote developments in fluorescence and ionization spectrometry and also in absorption techniques where uses of optical cavities for increased effective absorption path length are expected to expand. The use of plasma- and laser-based methods is increasing.

### **Nuclear magnetic resonance spectroscopy (NMR)**

NMR is an important technique to determine structure of drug molecules. During recent years, a variety of state-of-the art approaches have been presented and found a widespread application in both pharmaceutical and academic research. Recently NMR finds its application in quantitative analysis in order to determine the impurity of the drug, characterization of the composition of the drug products in pharmaceutical formulations and biological fluids.

### **Fluorimetry and phosphorimetry**

Scientists are continuously looking for the sensitive analytical techniques to analyze micro samples. Fluorescence spectrometry is one of the techniques that serve the purpose of high sensitivity without the loss of specificity or precision. Fluorimetry and phosphorimetry are playing important role in quantitative analysis of various drugs in dosage forms and in biological fluids.

## **ELECTROCHEMICAL ANALYSIS**

Electroanalytical methods measure the potential (volts) and/or current (amps) in an electrochemical cell containing the analyte. These methods can be categorized according to which aspects of the cell are controlled and which are measured. The three main categories are potentiometry (the difference in electrode potentials is measured), coulometry (the cell's current is measured over time), and voltammetry (the cell's current is measured while actively altering the cell's potential). The application of electrochemical techniques in the analysis of drugs and pharmaceuticals has increased greatly over the last few years. The renewed interest in electrochemical techniques can be attributed in part to more sophisticated instrumentation and to increase the understanding of the technique themselves. Moreover, a large number of electro-analytical methods are available for quantification of pharmaceuticals. The electrochemical behaviour of various drugs is investigated using cyclic voltammetry, chrono-coulometry, electrochemical impedance spectroscopy and adsorptive stripping differential pulse voltammetry.

## **THERMAL ANALYSIS**

Thermal analysis refers to the variety of techniques developed and used in which any physical property of a given system is continuously measured as a function of temperature, though temperature and time may be related by the term called the heating rate. Thermal analysis techniques are employed in virtually every area of modern science and technology. The basic information that the variety of techniques can provide includes crystallinity, specific heat, expansion and information on a variety of physical and chemical transformations that can take place on the sample under inspection.

## **KINETIC METHOD OF ANALYSIS**

Kinetic method of analysis has been developing since 1950s and yet in modern days it is taking a major resurgence. The increased interest in the kinetic methods can be credited to the advancements made in principles, in automated instrumentation, in understanding



the chemical and instrumentation, in data analysis methods and in the analytical application. The kinetic approach to analytical chemistry has several advantages over traditional equilibrium approach. Essentially, kinetic methods trust the measurements of concentration changes (detected via signal changes) in a reactant (which may be the analyte itself) with time after the sample and reagents have been mixed manually or mechanically. Automatic techniques for the kinetic methods are generally based on open systems, among the popular techniques are the stopped flow system and the continuous addition of reagent (CAR) technique. Several drugs have been determined by using the CAR technique with photometric and fluorimetric detection. The use of micellar media in kinetic method is used to increase the rate of reaction. Multicomponent kinetic estimations (differential rate methods) are also receiving wide acceptance in the field of pharmaceutical research. Two new approaches i.e. kinetic wavelength pair method and H-point standard addition method are applied for dealing with overlapping spectra of components in binary mixtures.

## **CHROMATOGRAPHIC TECHNIQUES**

There are several types of chromatographic techniques used in pharmaceutical analysis.

### **Thin layer chromatography (TLC)**

TLC is an old technique yet it finds a lot of application in the field of pharmaceutical analysis. In TLC, a solid phase, the adsorbent, is coated onto a solid support as a thin layer usually on a glass, plastic, or aluminum support. Several factors determine the efficiency of this type of chromatographic separation. First the adsorbent should show extreme selectivity toward the substances being separated so as to the dissimilarities in the rate of elution be large. For the separation of any given mixture, some adsorbents may be too strongly adsorbing or too weakly adsorbing.

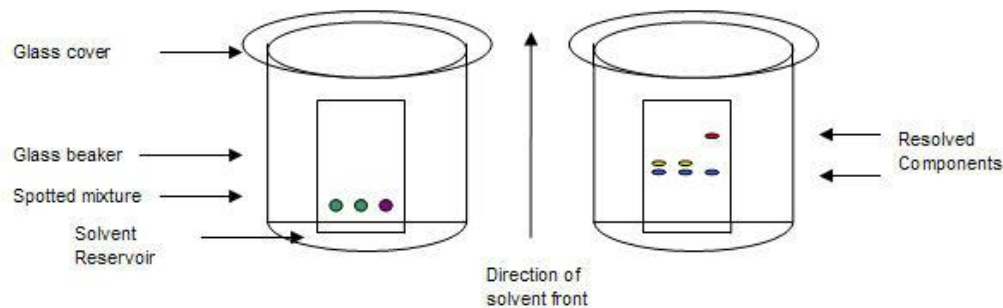

TLC is a popular technique for the analysis of a wide variety of organic and inorganic materials, because of its distinctive advantages such as minimal sample clean-up, wide choice of mobile phases, flexibility in sample distinction, high sample loading capacity and low cost. TLC is a powerful tool for screening unknown materials in bulk drugs. It provides a relatively high degree of assertion that all probable components of the drug are separated. The high specificity of TLC has been exploited to quantitative analytical purpose using spot elution followed by spectrophotometric measurement. TLC plays an important role in the early stage of drug development when information about the impurities and degradation products in drug substance and drug product is inadequate. Various impurities of pharmaceuticals are also identified and determined by TLC.

### **High performance thin layer chromatography (HPTLC)**

HPTLC emerged as an important instrument in drug analysis with the advancement of the TLC technique. HPTLC is a fast separation technique and flexible enough to analyze a wide variety of samples. This technique is advantageous in many means as it is simple to handle and requires a short analysis time to analyze the complex or the crude sample cleanup. HPTLC evaluates the entire chromatogram with a variety of parameters without time limits. Moreover, there is simultaneous but independent development of multiple samples and standards on each plate, leading to an increased reliability of results. HPTLC evaluates the entire chromatogram with a variety of parameters without time limits.

Moreover, there is simultaneous but independent development of multiple samples and standards on each plate, leading to an increased reliability of results.

### High performance liquid chromatography (HPLC)

HPLC is an advanced form of liquid chromatography used in separating the complex mixture of molecules encountered in chemical and biological systems. HPLC methods appeared for the first time in 1980 for the assay of bulk drug materials. The specificity of the HPLC method is excellent and simultaneously sufficient precision is also attainable. However, it has to be stated that the astonishing specificity, precision and accuracy are attainable only if wide-ranging system suitability tests are carried out before the HPLC analysis. For the reason the expense to be paid for high specificity, precision and accuracy is also high. HPLC has been the most widely used system among all the chromatographic techniques in present days. In liquid chromatography the choice of detection approach is critical to guarantee that all the components are detected. One of the widely used detectors in HPLC is UV detector which is capable of monitoring several wavelengths concurrently; this is possible only by applying a multiple wavelength scanning program. If present in adequate quantity, UV detector assures all the UV-absorbing components are detected. When a variable wavelength detector (VWD) is used a sample must be injected numerous times, with changing wavelength, to be sure that all the peaks are detected. However, the limitations of HPLC include price of columns, solvents and a lack of long term reproducibility due to the proprietary nature of column packing.

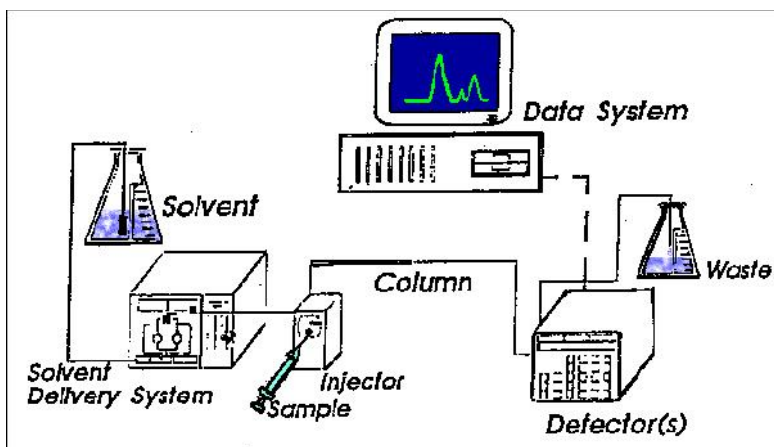

Liquid chromatography combined with mass spectrometry (LC–MS) is considered as one of the most important techniques of the last decade of 20th century. It became the method-of-choice for analytical support in many stages of quality control and assurance within the pharmaceutical industry.



Recently HPLC-MS has been used for assay of drugs and also to analyze the impurities of the pharmaceuticals.

### **Gas Chromatography (GC)**

GC is a powerful separation technique for detection of volatile organic compounds. Combining separation and on-line detection allows accurate quantitative determination of complex mixtures, including traces of compounds down to parts per trillions in some specific cases. Gas liquid chromatography commands a substantial role in the analysis of pharmaceutical product.



The creation of high-molecular mass products such as polypeptides, or thermally unstable antibiotics confines the scope of this technique. Its main constraint rests in the comparative non-volatility of the drug substances therefore, derivatization is virtually compulsory. Gas chromatography is also an important tool for analysis of impurities of pharmaceuticals. In recent years GC has been applied to estimate the process related impurities of the pharmaceuticals. Residual solvents present as impurity in different pharmaceuticals could also be analyzed by the GC.

## **ELECTROPHORESIS**

Electrophoresis is another important instrumental method of analysis of pharmaceuticals. One of the most popular electrophoresis techniques is capillary electrophoresis (CE). CE is based on the separation of charged molecules through a small capillary under the impact of an electric field. In this technique solutes are perceived as peaks as they pass through the detector and the area of individual peak is proportional to their concentration, which allows quantitative estimations. In addition to pharmaceutical studies it finds an application in the analysis of biopolymer analysis and inorganic ions.

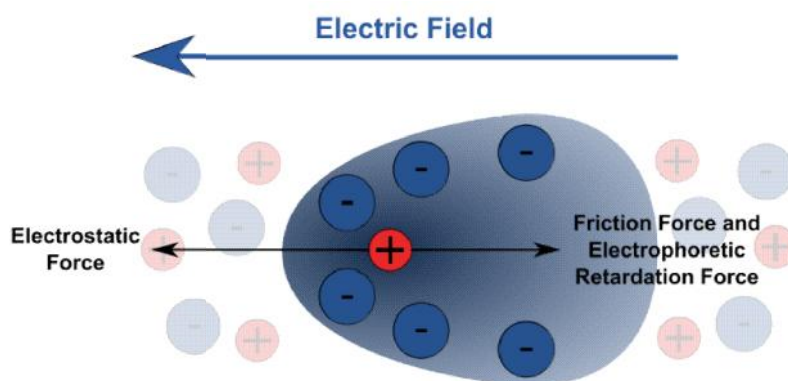

CE analysis is generally more effective, can be performed on a quicker time scale, requires only a small amount, lesser up to Nano liter injection volumes and in most cases, takes place under aqueous conditions.

### CE Principle

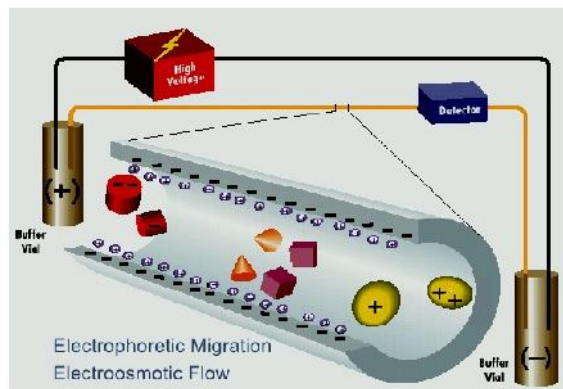

These four characteristics of CE have proven to be beneficial to many pharmaceutical applications including routine drug analysis.

### **FLOW INJECTION ANALYSIS**

The basis of Flow injection analysis (FIA) is injection of a liquid sample into a moving, non-segmented uninterrupted carrier stream of a suitable liquid. The injected sample forms a zone, which is then transported toward a detector that uninterruptedly records the

changes in absorbance, electrode potential, or other physical parameter resulting from the passage of the sample material through the flow cell. The FIA technique has lent a significant contribution to the advancement of automation in pharmaceutical analysis. The introduction of FIA has awakened the interest of the scientific community for automation in the pharmaceutical area.

## **MICROSCOPIC ANALYSIS**

The visualization of single molecules, single cells, biological tissues and nanomaterials is an important and attractive approach in analytical science. Also, hybridization with other traditional analytical tools is revolutionizing analytical science. Microscopy can be categorized into three different fields: optical microscopy, electron microscopy, and scanning probe microscopy.



Recently, this field is rapidly progressing because of the rapid development of the computer and camera industries. Microscopic analyses are applied to a wide variety of pharmaceuticals.

## **HYBRID TECHNIQUES**

Combinations of the above techniques produce a "hybrid" or "hyphenated" technique. Hyphenated separation technique refers to a combination of two (or more) techniques to detect and separate chemicals from solutions. Several examples are in popular use today and new hybrid techniques are under development, for example, gas chromatography-mass spectrometry (GC-MS), gas chromatography-infrared spectroscopy, liquid chromatography-mass spectrometry (LC-MS), liquid chromatography-NMR spectroscopy (LC-NMR), liquid chromatography-infrared spectroscopy, capillary electrophoresis-mass spectrometry and HPLC-MS/MS.

The determination of drugs in biological materials is an important step in drug discovery and drug development. HPLC together with various types of detection such as ultraviolet, fluorescence, and mass spectrometry has become the method of choice for bioanalytical method development. Liquid chromatography-electrospray ionization–mass spectrometry method is used for the qualitative and quantitative determination of metabolites of some drugs.

## **APPLICATIONS**

Analytical chemistry research is largely driven by performance (sensitivity, selectivity, robustness, linear range, accuracy, precision, and speed), and cost (purchase, operation, training, time, and space). Analytical chemistry has played critical roles in the understanding of basic science to a variety of practical applications, such as biomedical applications, environmental monitoring, quality control of industrial manufacturing, forensic science and so on.

Great efforts are put in shrinking the analysis techniques to chip size. Although there are few examples of such systems competitive with traditional analysis techniques, potential advantages include size/portability, speed, and cost. [micro Total Analysis



System ( $\mu$ TAS) or Lab-on-a-chip]. Microscale chemistry reduces the amounts of chemicals used.

Many developments improve the analysis of biological systems. Examples of rapidly expanding fields in this area are:

- Genomics - DNA sequencing and its related research. Genetic fingerprinting and DNA microarray are important tools and research fields.
  - Proteomics - the analysis of protein concentrations and modifications, especially in response to various stressors, at various developmental stages, or in various parts of the body.
  - Metabolomics - similar to proteomics, but dealing with metabolites.
  - Transcriptomics - mRNA and its associated field
  - Lipidomics - lipids and its associated field
  - Peptidomics - peptides and its associated field
  - Metalomics - similar to proteomics and metabolomics, but dealing with metal concentrations and especially with their binding to proteins and other molecules.
- 
- The recent developments of computer automation and information technologies have extended analytical chemistry into a number of new biological fields. For example, automated DNA sequencing machines were the basis to complete human genome projects leading to the birth of genomics. Protein identification and peptide sequencing by mass spectrometry opened a new field of proteomics.
- 
- Analytical chemistry has been an indispensable area in the development of nanotechnology. Surface characterization instruments, electron microscopes and scanning probe microscopes enables scientists to visualize atomic structures with chemical characterizations.

### 3. SAFETY NOTES

While working in a chemistry laboratory, students should be very careful in doing experiments, and keep in mind the following points-

- Many solvents like acetone, alcohols, phenols, and ethers are toxic, and all are flammable.
- Use these chemicals only in well-ventilated space. Keep away from flames and other sources of ignition.
- *Sodium* hydroxide is corrosive and can cause burns. Use great care to avoid contact with skin, eyes, and clothing. In case of accidental contact, flood the affected area with copious amounts of water. Spills should be diluted with water and cleaned up immediately.



- Elemental Na reacts violently and exothermically with water or oxygen, producing strongly corrosive NaOH and H<sub>2</sub> gas. The latter can ignite spontaneously in this exothermic reaction. Therefore, never leave unprotected Na anywhere and avoid allowing it to come in contact with water.
- Bromine is corrosive and causes serious burns. Use great care *to* avoid contact with skin, eyes, and clothing. In case of accidental contact, flood the affected area with copious amounts of water and seek medical attention.

- Chromium is highly toxic and the acid solution is extremely corrosive. Avoid ingestion. Handle only with gloves. Use great care *to* avoid contact with skin, eyes, and clothing. In case of accidental contact, flood the affected area with copious amounts of water. In case of ingestion, seek medical attention immediately.
- The zinc chloride/hydrogen chloride solution is corrosive and causes burns. Use great care *to* avoid contact with skin, eyes, and clothing. In case of accidental contact, flood the affected area with copious amounts of water. Spills should be diluted with water and cleaned up immediately.
- Smoking is not allowed in the laboratory.
- Know the location of fire extinguishers and how to use them. Report all accidents immediately to the instructor.
- If any person has hair or clothing on fire, as a first step, lie down on the floor and use a blanket, coat or anything available to smother the flames. Get help immediately.
- Never taste any solid or liquid chemical. When smelling a substance do not hold your face directly over the container.
- Most organic substances are hazardous to health; so avoid breathing and skin contact as much as possible. It is advisable to wear safety glasses in the laboratory.
- In some cases a trap must be used to prevent hazardous gases from escaping into the laboratory atmosphere.
- If acids or corrosive chemicals are spilled on your skin, wash with plenty of cold water then consult your instructor.
- Do not point your test tube at your neighbor or yourself when heating substances.
- Most organic solvents are flammable, so never heat a flammable substance with a direct flame. A hot water bath is used instead.
- Experiments should never be left unattended. Always wear a laboratory coat.
- If acid or base is spilled on your clothing, bench or floor wash thoroughly with water, then neutralize with dilute ammonium hydroxide or acetic acid respectively and inform your instructor.
- Always wash your hands with soap and water on leaving the laboratory.
- Do not use cell-phone (mobile phone) in the laboratory.

## 4. COMMON LABORATORY PROCESSES

There are a number of laboratory processes or techniques. Some common laboratory procedures are given below:

### HEATING PROCESS

There are various heating devices in an analytical chemistry laboratory. The Bunsen burner and water bath are the most commonly used. A limitation of the Bunsen burner is that it should not be used directly for heating flammable solvents. Wire gauze is used over the flame for heating conical flasks, beaker, etc. Flammable and volatile liquids are heated in a water bath when temperatures under 100 °C are required. If an electrical steam bath is not available, a large beaker filled with water may be used instead. It is heated to boiling with a Bunsen burner and the flame extinguished before heating the flammable liquid in the bath. Bumping may be prevented by continuous stirring to ensure homogenous and steady heating of the liquid or by the use of boiling stones which achieve a similar effect through formation of bubbles.

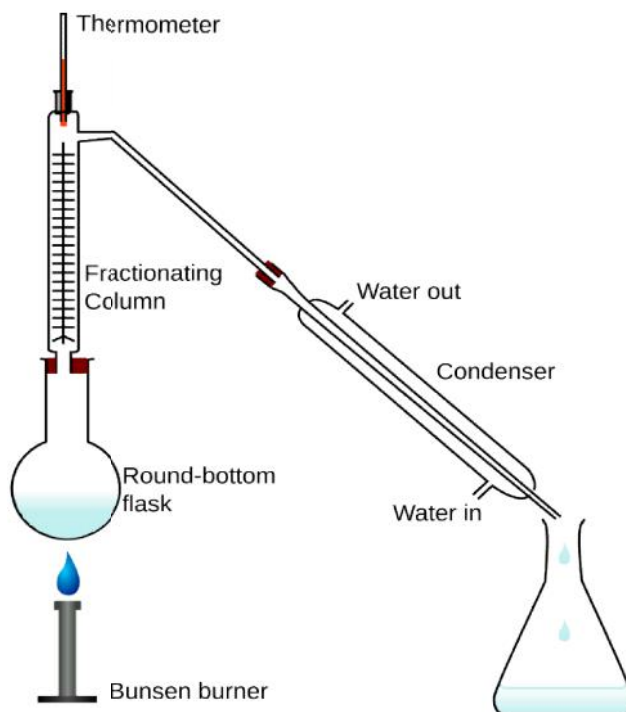

The technique of refluxing is commonly used when it is necessary to heat a reaction in order to bring it to completion in a reasonable time span. A reflux condenser is used to minimize loss, through evaporation, of volatile reactants, products or solvent by allowing the vapors to recondense and return to the reaction vessel

## **HANDLING OF GLASS WARES**

Used glassware may be cleaned with soap and water using a brush. However, glassware which has tough stains from organic substances requires soaking in the solution of chromic acid. This mixture has to be used carefully as it is very corrosive. Glass tubing with unpolished ends is a hazard since it can cause serious cuts when trying to insert it into a cork. Therefore, only glass tubing with polished ends must be used. When forcing glass tubing into a cork, grasp it as close as possible to the cork and be careful not to break it. Quickfit glass joints should always be lubricated with a suitable lubricant (grease). A thin film of grease is applied to the joints to provide an air-tight seal and to prevent the joints from being stuck together. There should be no excess grease extending inside the apparatus as it might contaminate the reaction mixture. It is also recommended that old grease be wiped off with a piece of tissue paper before applying a new film.

## **FILTRATION**

Filtration is a mechanical or physical process which is used for the separation of solids from fluids (liquids or gases) by interposing a medium through which only the fluid can pass. The fluid that passes through is called the filtrate.



Oversize solids in the fluid are retained, but the separation is not complete; solids will be contaminated with some fluid and filtrate will contain fine particles (depending on the pore size and filter thickness).

Filtration is used whenever an insoluble solid is to be separated from a liquid. Simple gravity filtration (usually hot filtration) is employed to remove insoluble solid impurities from a liquid, while suction filtration (usually cold filtration) is used to collect a desired solid or crystalline product. Vacuum filtration is also used for speedy filtration.

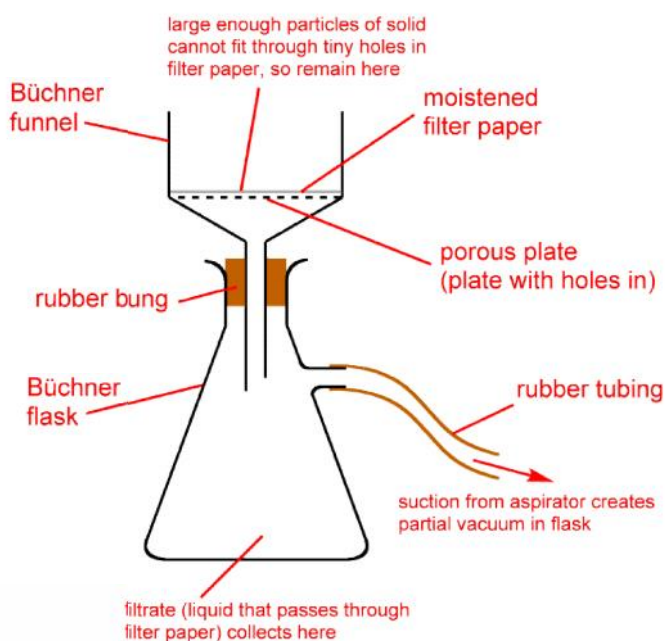

Decolorization is the removal of colored impurities from a solution. This is achieved by the addition of activated charcoal to the solution and mixing thoroughly. If charcoal is added to a cold solution, the solution is first brought to a boil before hot filtration. Whenever it is added to a hot solution, the flask should be removed from the heat source before the addition, otherwise bumping will occur. Charcoal is finally removed by filtration leaving an almost colorless solution.

## **DRYING**

The process of drying, if applied to a solid substance is aimed to remove residual solvent (organic or water) adhering to the solid particles/ crystals. This is usually done by air drying (spreading over a sheet of paper/filter paper) and/or heating in an oven to enhance evaporation of the solvent. Drying of an organic liquid, however, involves the removal of traces of water (moisture) using chemical drying agents. Such cases are encountered in extraction where the organic phase is in direct contact with the aqueous phase. After separating the layers, traces of water in the organic phase are removed by the addition of a suitable drying agent. Some common examples are: calcium chloride, magnesium sulfate, sodium sulfate, sodium hydroxide and potassium hydroxide.

## **MELTING POINT DETERMINATION**

The melting point of a solid is the temperature at which transition from solid to liquid occurs at atmospheric pressure; or the temperature at which solid and liquid phases are in equilibrium at a pressure of one atmosphere. A simple device for determining melting points is used and it consists of a thermometer fitted through a cork and suspended into a long-necked flask which is three quarters filled with a high boiling and stable liquid like paraffin oil, di-butylphthalate or silicon oil. The thermometer bulb should be about 1 cm above the bottom of the flask. The sample in the capillary tube is fastened to the thermometer with a rubber band placed above the level of the oil. The capillary tube should be close to and on a level with the thermometer bulb.



To determine the melting point of a solid, a small amount of the powdered substance is introduced into a capillary tube which is then attached to a thermometer and placed in the oil bath. The bath is heated rapidly to within 20 °C of the expected melting point then slowly, and at a constant rate of 2-3 degrees per minute, close to the melting point. The temperature at which the solid begins to melt, and that at which it is completely liquid, is recorded as the melting point range of that substance.

## **BOILING POINT DETERMINATION**

The boiling point of a liquid is defined as the temperature at which the vapor pressure of the liquid equals the external pressure (usually 1 atmosphere). It is also defined as the temperature at which vapor and liquid are in equilibrium at a given pressure. The boiling point, like the melting point, is a physical constant and may be used to identify unknown organic liquids. Distillation is the process of heating a liquid to its boiling point, condensing the vapor by cooling, and collecting the liquid distillate. It is a technique for the purification of liquids and for the separation of liquid mixtures. As the distillation progresses, the mixture will gradually have less of the more volatile component and its boiling point will gradually rise. Consequently the distillate will contain a continually decreasing proportion of the more volatile component until finally all has been collected and the less volatile component is left as a residue.





In practice, separation of a liquid mixture into its components by a single distillation (simple distillation) is possible only when the boiling points of the components are 80 degrees or more apart. For mixtures of liquids having boiling points much less than 80 degrees apart, separation can be achieved only by fractional distillation. Such a distillation is equivalent to several repeated simple distillations. It uses a fractionating column which provides a large surface area for continuous heat exchange between the hot ascending vapor and the cooler descending liquid, thus resulting in a series of evaporations and condensations leading to separation of the two components. Vacuum distillation is a technique for the distillation of high boiling liquids, and for compounds that decompose at atmospheric pressure. At the low pressures employed, those compounds distil at much lower temperatures.

## **CHROMATOGRAPHY**

Chromatography is a technique that may be used to separate the components of a mixture as well as to identify organic substances and examine their purity. Chromatography encompasses several techniques such as column, thin-layer, paper, gas liquid, etc. chromatography. Two principles are basically involved in chromatography: adsorption (as in thin layer chromatography) and partition (as in paper chromatography), and certain terms are common to both types of chromatography.

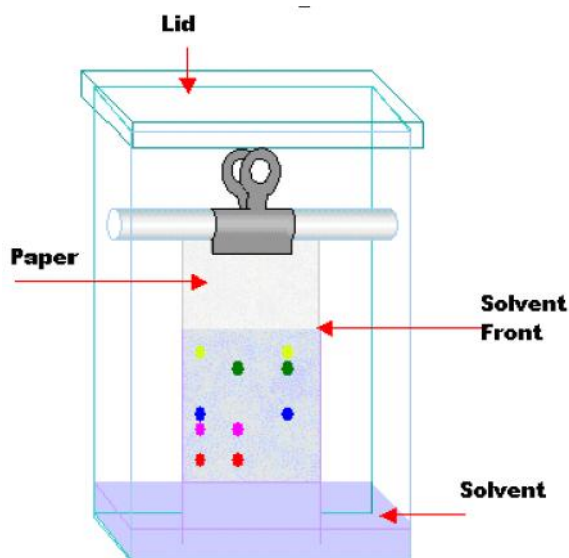

In adsorption chromatography, separation depends on the selective desorption of the components of a mixture by the eluent (mobile phase) from the surface of a solid adsorbent (stationary phase). The adsorbent may be packed in a column (column chromatography) or spread as a thin layer on a glass plate as in thin-layer chromatography.

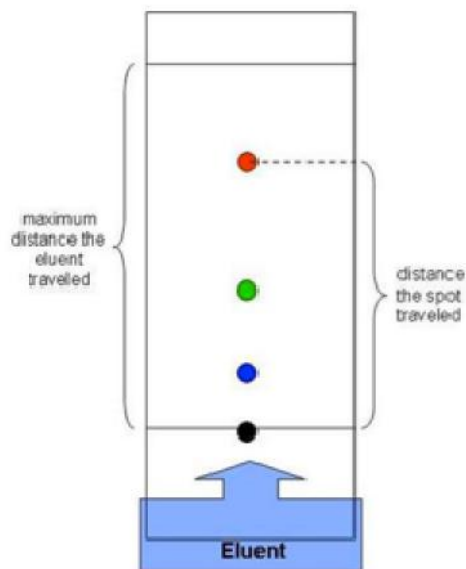

In partition chromatography, separation depends on partition of the components of a mixture between the stationary and mobile phases. The mobile phase may be a liquid (liquid-liquid partition chromatography) or a gas (gas-liquid partition chromatography). Modern pharmaceutical analytical chemistry lab has almost all types of instruments of different chromatographic techniques. Students should handle these sophisticated instruments with utmost care.

## 5. COMMON LABORATORY APPARATUSES

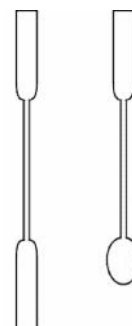
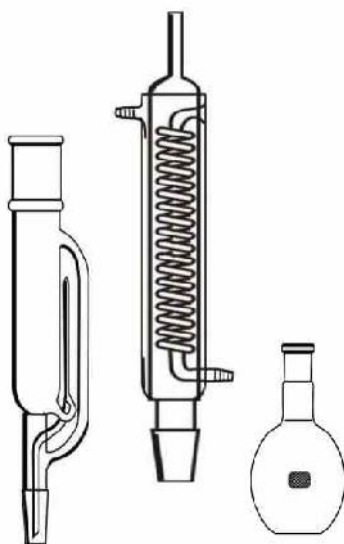
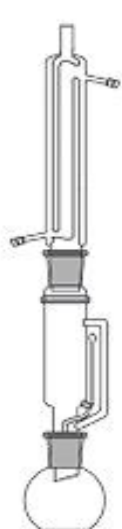

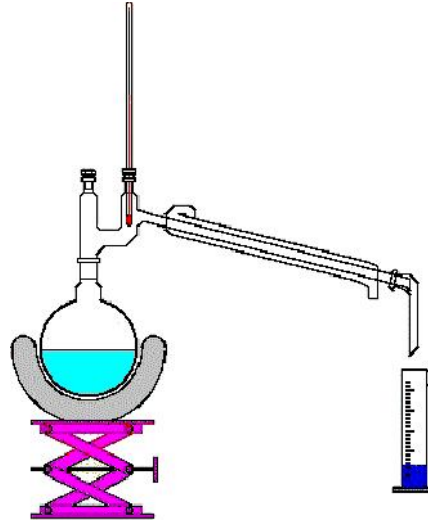

## 6. LIMIT TESTS

### Definition

Limit = a value or amount that is likely to be present in a substance

Test = to examine or to investigate

Impurities = a foreign matter present in a compound

Every pharmaceutical substance contains some impurities varying in proportion. Indian Pharmacopoeia (IP) has fixed a limit of these impurities. To see the limit, some official tests are carried out, these tests are known as limit tests. Limit test is defined as quantitative or semi quantitative test designed to identify and control small quantities of impurity which is likely to be present in the substance.

Limit test is generally carried out to determine the inorganic impurities present in compound. In short, limit test is nothing but to identify the impurities present in the substance and compare it with standard.

Importance of Limit tests:

To find out the harmful amount of impurities

To find out the avoidable/unavoidable amount of impurities.

Limit tests involve the comparison of opalescence, turbidity or colour with the standard.

### LIMIT TEST OF CHLORIDE

#### Principle:

Limit test of chloride is based on the reaction of soluble chloride with silver nitrate in presence of dilute nitric acid to form silver chloride, which appears as solid particles (Opalescence) in the solution.



### Procedure:

Test sample	Standard
Specific weight of compound is dissolved in water or solution is prepared as directed in the pharmacopoeia and transferred in Nessler cylinder	Take 1ml of 0.05845 % W/V solution of sodium chloride in Nessler cylinder
Add 1ml of nitric acid	Add 1ml of nitric acid
Dilute to 50ml in Nessler cylinder	Dilute to 50ml in Nessler cylinder
Add 1ml of AgNO <sub>3</sub> solution	Add 1ml of AgNO <sub>3</sub> solution
Keep aside for 5 min	Keep aside for 5 min
Observe the Opalescence/Turbidity	Observe the Opalescence/Turbidity

### Observation:

The opalescence produced in sample solution should not be greater than standard solution. If opalescence in sample solution is less than the standard solution, the sample will pass the limit test of chloride and vice-versa.

### Reasons:

Nitric acid is added in the limit test of chloride to make solution acidic and helps silver chloride precipitate to make solution turbid at the end of process.

## LIMIT TEST OF SULPHATE

### Principle:

Limit test of sulphate is based on the reaction of soluble sulphate with barium chloride in presence of dilute hydrochloric acid to form barium sulphate which appears as solid particles (turbidity) in the solution.



**Procedure:**

Test sample	Standard
Specific weight of compound is dissolved in water or solution is prepared as directed in the pharmacopoeia and transferred in Nessler cylinder	Take 1ml of 0.1089 % W/V solution of potassium sulphate in Nessler cylinder
Add 2ml of dilute hydrochloric acid	Add 2ml of dilute hydrochloric acid
Dilute to 45 ml in Nessler cylinder	Dilute to 45 ml in Nessler cylinder
Add 5ml of barium sulphate reagent	Add 5ml of barium sulphate reagent
Keep aside for 5 min	Keep aside for 5 min
Observe the Turbidity	Observe the Turbidity

Barium sulphate reagent contains barium chloride, sulphate free alcohol and small amount of potassium sulphate.

**Observation:**

The turbidity produce in sample solution should not be greater than standard solution. If turbidity produces in sample solution is less than the standard solution, the sample will pass the limit test of sulphate and vice versa.

**Reasons:**

Hydrochloric acid helps to make solution acidic.

Potassium sulphate is used to increase the sensitivity of the test by giving ionic concentration in the reagent. Alcohol helps to prevent super saturation.

## LIMIT TEST OF IRON

### Principle:

Limit test of Iron is based on the reaction of iron in ammonical solution with thioglycollic acid in presence of citric acid to form iron thioglycolate which is pale pink to deep reddish purple in color.

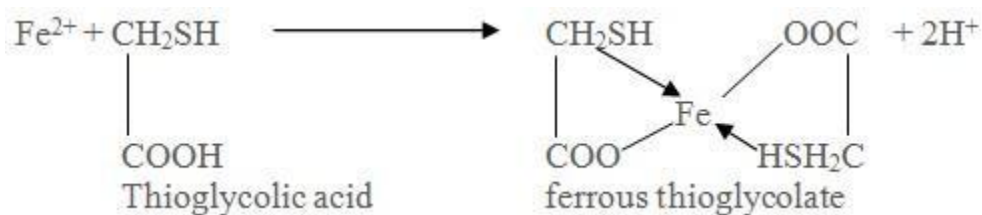

### Procedure:

Test sample	Standard
Sample is dissolved in specific amount of water and then volume is made up to 40 ml	2 ml of standard solution of iron diluted with water upto 40ml
Add 2 ml of 20 % w/v of citric acid (iron free)	Add 2 ml of 20 % w/v of citric acid (iron free)
Add 2 drops of thioglycollic acid	Add 2 drops of thioglycollic acid
Add ammonia to make the solution alkaline and adjust the volume to 50 ml	Add ammonia to make the solution alkaline and adjust the volume to 50 ml
Keep aside for 5 min	Keep aside for 5 min
Color developed is viewed vertically and compared with standard solution	Color developed is viewed vertically and compared with standard solution



Earlier ammonium thiocyanate reagent was used for the limit test of iron. Since thioglycolic acid is more sensitive reagent, it has replaced ammonium thiocyanate in the test.

**Observation:**

The purple color produced in sample solution should not be greater than standard solution. If purple color produced in sample solution is less than the standard solution, the sample will pass the limit test of iron and vice versa.

**Reasons:**

Citric acid helps precipitation of iron by ammonia by forming a complex with it. Thioglycolic acid helps to oxidize iron (II) to iron (III). Ammonia to make solution alkaline.

**LIMIT TEST OF HEAVY METALS**

**Principle:**

Limit test of heavy metals is based on the reaction of metallic impurities with hydrogen sulfide in acidic medium to form brownish colour solution. Metals that respond to this test are lead, mercury, bismuth, arsenic, antimony, tin, cadmium, silver, copper, and molybdenum. The metallic impurities in substances are expressed as parts of lead per million parts of the substance. The usual limit as per Indian Pharmacopoeia is 20 ppm

**Procedure:**

The Indian Pharmacopoeia has adopted three methods for the limit test of heavy metals.

**Method I:** Use for the substance which gives clear colorless solution under the specific condition.

<b>Test sample</b>	<b>Standard</b>
Solution is prepared as per the monograph and 25 ml is transferred in Nessler's cylinder	Take 2 ml of standard lead solution and dilute to 25 ml with water

Adjust the pH between 3 to 4 by adding dilute acetic acid 'Sp' or dilute ammonia solution 'Sp'	Adjust the pH between 3 to 4 by adding dilute acetic acid 'Sp' or dilute ammonia solution 'Sp'
Dilute with water to 35 ml	Dilute with water to 35 ml
Add freshly prepared 10 ml of hydrogen sulphide solution	Add freshly prepared 10 ml of hydrogen sulphide solution
Dilute with water to 50 ml	Dilute with water to 50 ml
Allow to stand for five minutes	Allow to stand for five minutes
View downwards over a white surface	View downwards over a white surface

**Observation:**

The color produce in sample solution should not be greater than standard solution. If color produces in sample solution is less than the standard solution, the sample will pass the limit test of heavy metals and vice versa.

**Method II:** Use for the substance which do not give clear colorless solution under the specific condition.

<b>Test sample</b>	<b>Standard</b>
Weigh specific quantity of test substance, moisten with sulphuric acid and ignite on a low flame till completely charred Add few drops of nitric acid and heat to 500 °C Allow to cool and add 4 ml of hydrochloric acid and evaporate to dryness Moisten the residue with 10 ml of hydrochloric acid and digest for two minutes Neutralize with ammonia solution and make just acid with acetic acid	Take 2 ml of standard lead solution and dilute to 25 ml with water
Adjust the pH between 3 to 4 and filter if	Adjust the pH between 3 to 4 by

necessary	adding dilute acetic acid 'Sp' or dilute ammonia solution 'Sp'
Dilute with water to 35 ml	Dilute with water to 35 ml
Add freshly prepared 10 ml of hydrogen sulphide solution	Add freshly prepared 10 ml of hydrogen sulphide solution
Dilute with water to 50 ml	Dilute with water to 50 ml
Allow to stand for five minutes	Allow to stand for five minutes
View downwards over a white surface	View downwards over a white surface

**Observation:**

The color produce in sample solution should not be greater than standard solution. If color produces in sample solution is less than the standard solution, the sample will pass the limit test of heavy metals and vice versa.

**Method III:** Use for the substance which gives clear colorless solution in sodium hydroxide solution.

<b>Test sample</b>	<b>Standard</b>
Solution is prepared as per the monograph and 25 ml is transferred in Nessler's cylinder or weigh specific amount of substance and dissolve in 20 ml of water and add 5 ml of dilute sodium hydroxide solution	Take 2 ml of standard lead solution
Make up the volume to 50 ml with water	Add 5 ml of dilute sodium hydroxide solution and make up the volume to 50 ml with water
Add 5 drops of sodium sulphide solution	Add 5 drops of sodium sulphide solution
Mix and set aside for 5 min	Mix and set aside for 5 min
View downwards over a white surface	View downwards over a white surface

### Observation:

The color produce in sample solution should not be greater than standard solution. If color produces in sample solution is less than the standard solution, the sample will pass the limit test of heavy metals and vice versa.

### LIMIT TEST OF LEAD

Lead is a most undesirable impurity in medical compounds and comes through use of sulphuric acid, lead lined apparatus and glass bottles use for storage of chemicals.

### Principle:

Limit test of lead is based on the reaction of lead and diphenyl thiocabazone (dithizone) in alkaline solution to form lead dithizone complex which is read in color. Dithizone is green in color in chloroform and lead-dithizone complex is violet in color, so the resulting color at the end of process is red.

### Procedure:

Test sample	Standard
A known quantity of sample solution is transferred in a separating funnel	A standard lead solution is prepared equivalent to the amount of lead permitted in the sample under examination
Add 6ml of ammonium citrate	Add 6ml of ammonium citrate
Add 2 ml of potassium cyanide and 2 ml of hydroxylamine hydrochloride	Add 2 ml of potassium cyanide and 2 ml of hydroxylamine hydrochloride
Add 2 drops of phenol red	Add 2 drops of phenol red
Make solution alkaline by adding ammonia solution.	Make solution alkaline by adding ammonia solution.

Extract with 5 ml of dithizone until it becomes green	Extract with 5 ml of dithizone until it becomes green
Combine dithizone extracts are shaken for 30 mins with 30 ml of nitric acid and the chloroform layer is discarded	Combine dithizone extracts are shaken for 30 mins with 30 ml of nitric acid and the chloroform layer is discarded
To the acid solution add 5 ml of standard dithizone solution	To the acid solution add 5 ml of standard dithizone solution
Add 4 ml of ammonium cyanide	Add 4 ml of ammonium cyanide
Shake for 30 mins	Shake for 30 mins
Observe the color	Observe the color

### **Observation:**

The intensity of the color of complex, is depends on the amount of lead in the solution. The color produce in sample solution should not be greater than standard solution. If color produces in sample solution is less than the standard solution, the sample will pass the limit test of lead and vice versa.

### **Reasons:**

Ammonium citrate, potassium cyanide, hydroxylamine hydrochloride is used to make pH optimum so interference and influence of other impurities have been eliminated. Phenol red is used as indicator to develop the color at the end of process Lead present as an impurities in the substance, gets separated by extracting an alkaline solution with a dithizone extraction solution.

## **LIMIT TEST OF ARSENIC**

### **Principle:**

Limit test of Arsenic is based on the reaction of arsenic gas with hydrogen ion to form yellow stain on mercuric chloride paper in presence of reducing agents like potassium

iodide. It is also called as Gutzeit test and requires special apparatus. Arsenic, present as arsenic acid in the sample is reduced to arsenious acid by reducing agents like potassium iodide, stannous acid, zinc, hydrochloric acid, etc. Arsenious acid is further reduced to arsine (gas) by hydrogen and reacts with mercuric chloride paper to give a yellow stain.

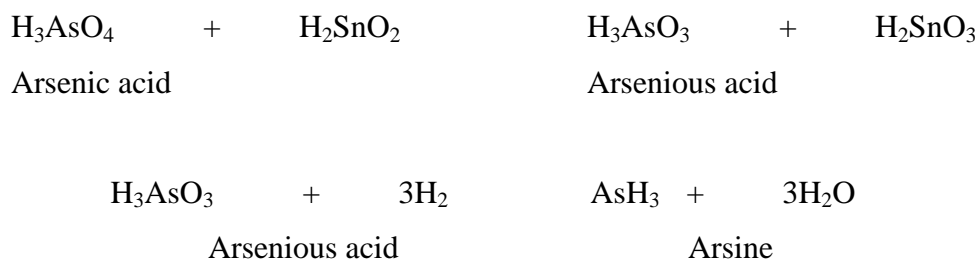

The depth of yellow stain on mercuric chloride paper will depend upon the quality of arsenic present in the sample.

**Procedure:**

**Test solution:**

The test solution is prepared by dissolving specific amount in water and stannated HCl (arsenic free) and kept in a wide mouthed bottle.

To this solution 1 gm of KI, 5 ml of stannous chloride acid solution and 10 gm of zinc is added (all this reagents must be arsenic free).

Keep the solution aside for 40 min and stain obtained on mercuric chloride paper is compared with standard solution.

**Standard solution:**

A known quantity of dilute arsenic solution is kept in wide mouthed bottle and rest procedure is followed as described in test solution.

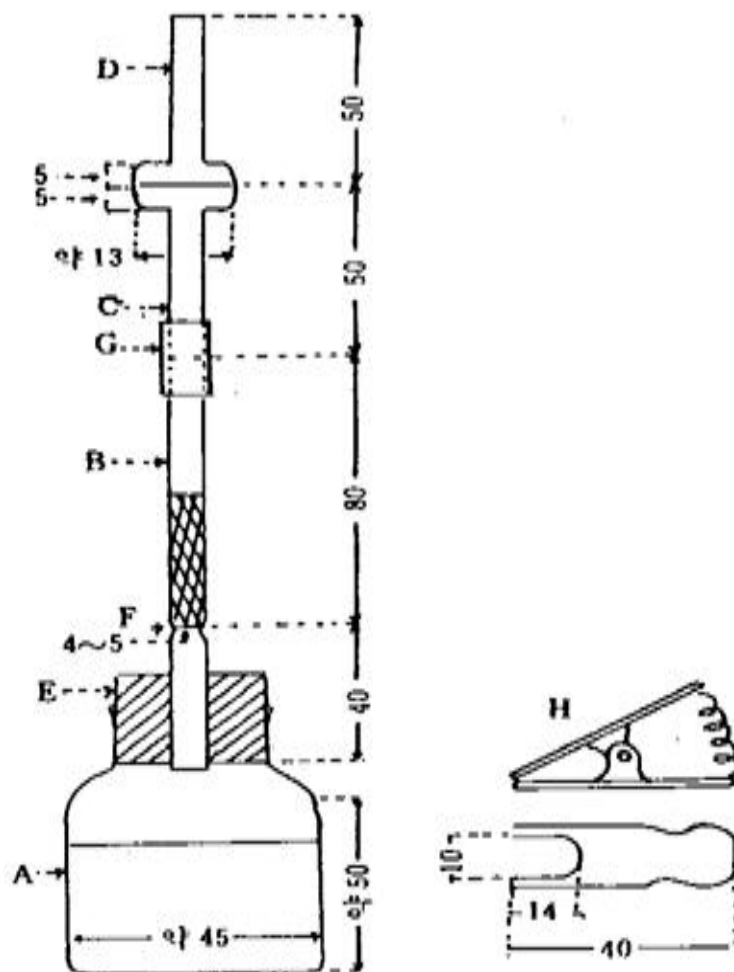

A : approximately 60 ml generator bottle with 40 ml indicating line.

B : glass tube with 6.5 mm inner diameter

C and D : a ground joint glass tube with 6.5 mm inner diameter and 18 mm outer diameter at the joint. Inner joint and the outer joint form a concentric circle.

E : rubber stopper

F : narrow part of the glass tube B. Glass wool is inserted up to this part.

G : rubber board (Lead acetate cotton plug)

H : clamp

### Reasons:

Stannous chloride is used for complete evolution of arsine

Zinc, potassium iodide and stannous chloride is used as a reducing agent

Hydrochloric acid is used to make the solution acidic  
Lead acetate pledger or papers are used to trap any hydrogen sulphide which may be evolved along with arsine.



## 7. BASIC CONCEPTS OF SPECTROSCOPIC AND CHROMATOGRAPHIC TECHNIQUES

### *ULTRA-VIOLET SPECTROSCOPY (UV-Spectroscopy):*

Molecular absorption spectroscopy in the ultraviolet and visible spectral regions is widely used for the quantitative determination of a large number of inorganic, organic and biological species. The molecular absorption is studied in the wavelength region of 190 to 800 nm. Ultraviolet and visible spectrometers have been in general use since long and over this period have become the most important analytical instrument in the modern day laboratory. In many applications other techniques could be employed but none rival UV-Visible spectrometry for its simplicity, versatility, speed, accuracy and cost-effectiveness.

#### **Principle:**

Molecular absorption spectroscopy is based on the measurement of transmittance (T) or the absorbance (A) of solutions contained in transparent cells having a path length of b centimeters. Ordinarily, the concentration of an absorbing analyte is linearly related to absorbance as given by Beer's Law:

$$A = -\log T = \log \frac{p_0}{p} = \epsilon bc$$

Where,

p <sub>0</sub> = incident radiant power,	b = path length of sample,
c = concentration of absorber,	e = molar absorptivity
p = transmitted radiant power,	A = absorbance,
T = transmittance	

Following photo is one of the UV-spectrometers available in the market-



### **Applications of UV Spectroscopy:**

Although UV Spectroscopy is classical method of analysis, it is still efficiently applied for a variety of procedures with success-

#### **1. Detection of Impurities**

UV absorption spectroscopy is one of the best methods for determination of impurities in organic molecules. Additional peaks can be observed due to impurities in the sample and it can be compared with that of standard raw material. Impurities can be detected by measuring the absorbance at specific wavelength. Benzene appears as a common impurity in cyclohexane. Its presence can be easily detected by its absorption at 255 nm.

#### **2. Structure elucidation of organic compounds.**

UV spectroscopy is useful in the structure elucidation of organic molecules, the presence or absence of unsaturation, the presence of hetero atoms. From the location of peaks and combination of peaks, it can be concluded that whether the compound is saturated or unsaturated, hetero atoms are present or not, etc.

### 3. Qualitative analysis

UV absorption spectroscopy can characterize those types of compounds which absorb UV radiation. Identification is done by comparing the absorption spectrum with the spectra of known compounds. UV absorption spectroscopy is generally used for characterizing aromatic compounds and aromatic olefins.

### 4. Quantitative analysis

UV absorption spectroscopy can be used for the quantitative determination of compounds that absorb UV radiation. This determination is based on Beer's law. Other methods for quantitative analysis are as follows.

- a. calibration curve method
- b. simultaneous multi component method
- c. difference spectrophotometric method
- d. derivative spectrophotometric method

### 5. Dissociation constants of acids and bases

$$\text{pH} = \text{PKa} + \log \frac{[\text{A}^-]}{[\text{HA}]}$$

From the above equation, the PKa value can be calculated if the ratio of  $[\text{A}^-]/[\text{HA}]$  is known at a particular pH. and the ratio of  $[\text{A}^-]/[\text{HA}]$  can be determined spectrophotometrically from the graph plotted between absorbance and wavelength at different pH values.

### 6. Chemical kinetics

Kinetics of reaction can also be studied using UV spectroscopy. The UV radiation is passed through the reaction cell and the absorbance changes can be observed.

## 7. Quantitative analysis of pharmaceutical substances

Many drugs are either in the form of raw material or in the form of formulation. They can be assayed by making a suitable solution of the drug in a solvent and measuring the absorbance at specific wavelength. Diazepam tablet can be analyzed by 0.5% H<sub>2</sub>SO<sub>4</sub> in methanol at the wavelength 284 nm.

## 8. Molecular weight determination

Molecular weights of compounds can be measured spectrophotometrically by preparing the suitable derivatives of these compounds. For example, if we want to determine the molecular weight of amine then it is converted in to amine picrate. Then known concentration of amine picrate is dissolved in a litre of solution and its optical density is measured at  $\lambda_{max}$  380 nm. After this the concentration of the solution in gm moles per litre can be calculated by using the following formula.

## 9. As HPLC detector

A UV/Vis spectrophotometer may be used as a detector for HPLC. The presence of an analyte gives a response which can be assumed to be proportional to the concentration. For more accurate results, the instrument's response to the analyte in the unknown should be compared with the response to a standard; as in the case of calibration curve.

## ***INFRA RED SPECTROSCOPY (IR Spectroscopy):***

The light our eyes see is a small part of a broad spectrum of electromagnetic radiation. Electromagnetic spectrum refers to the seemingly diverse collection of radiant energy, from cosmic rays to X-rays to visible light to microwaves, each of which can be considered as a wave or particle traveling at the speed of light. These waves differ from each other in the length and frequency.

On the immediate high energy side of the visible spectrum lies the ultraviolet, and on the low energy side is the infrared. The portion of the infrared region most useful for analysis of organic compounds is adjacent to the visible spectrum. An important tool of the organic chemist is Infrared Spectroscopy, or IR. IR spectra are acquired on a special instrument, called an IR spectrometer. IR is used both to gather information about the structure of a compound and as an analytical tool to assess the purity of a compound. IR spectra are quick and easy to run.



### **Principle:**

Infrared radiation is absorbed by organic molecules and converted into energy of molecular vibration. In IR spectroscopy, an organic molecule is exposed to infrared radiation. When the radiant energy matches the energy of a specific molecular vibration, absorption occurs. As with all spectroscopic techniques, it can be used to identify and study chemicals. A common laboratory instrument that uses this technique is a Fourier transform infrared (FTIR) spectrometer.

The infrared portion of the electromagnetic spectrum is usually divided into three regions; the near-, mid- and far- infrared, named for their relation to the visible spectrum. The higher-energy near-IR, approximately  $14000\text{--}4000\text{ cm}^{-1}$  ( $0.8\text{--}2.5\text{ }\mu\text{m}$  wavelength) can excite overtone or harmonic vibrations. The mid-infrared, approximately  $4000\text{--}400\text{ cm}^{-1}$  ( $2.5\text{--}25\text{ }\mu\text{m}$ ) may be used to study the fundamental vibrations and associated rotational-vibrational structure. The far-infrared, approximately  $400\text{--}10\text{ cm}^{-1}$  ( $25\text{--}1000$

$\mu\text{m}$ ), lying adjacent to the microwave region, has low energy and may be used for rotational spectroscopy.

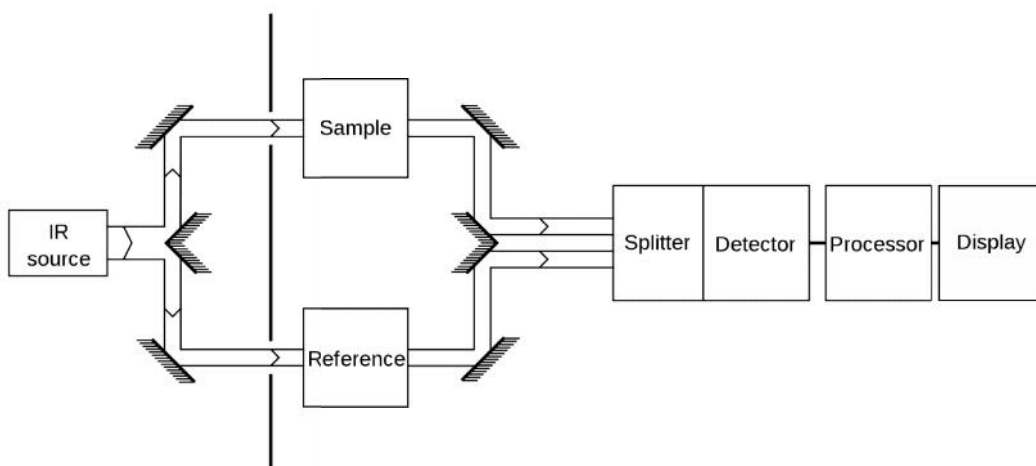

Most organic compounds have C-H bonds, a useful rule is that absorption in the 2850 to 3000  $\text{cm}^{-1}$  is due to  $\text{sp}^3\text{C-H}$  stretching; whereas, absorption above 3000  $\text{cm}^{-1}$  is from  $\text{sp}^2\text{C-H}$  stretching or  $\text{spC-H}$  stretching if it is near 3300  $\text{cm}^{-1}$ .

### Number of vibration modes

In order for a vibration mode in a molecule to be "IR active," it must be associated with changes in the permanent dipole.

A molecule can vibrate in many ways, and each way is called a vibrational mode. Linear molecules have  $3N-5$  degrees of vibrational modes whereas nonlinear molecules have  $3N-6$  degrees of vibrational modes (also called vibrational degrees of freedom). As an example  $\text{H}_2\text{O}$ , a non-linear molecule, will have  $3 \times 3 - 6 = 3$  degrees of vibrational freedom, or modes.

Simple diatomic molecules have only one bond and only one vibrational band. If the molecule is symmetrical, e.g.  $\text{N}_2$ , the band is not observed in the IR spectrum, but only in the Raman spectrum. Unsymmetrical diatomic molecules, e.g.  $\text{CO}$ , absorb in the IR spectrum. More complex molecules have many bonds, and their vibrational spectra are

correspondingly more complex, i.e. big molecules have many peaks in their IR spectra. The atoms in a CH<sub>2</sub> group, commonly found in organic compounds, can vibrate in six different ways: symmetric and antisymmetric stretching, scissoring, rocking, wagging and twisting.

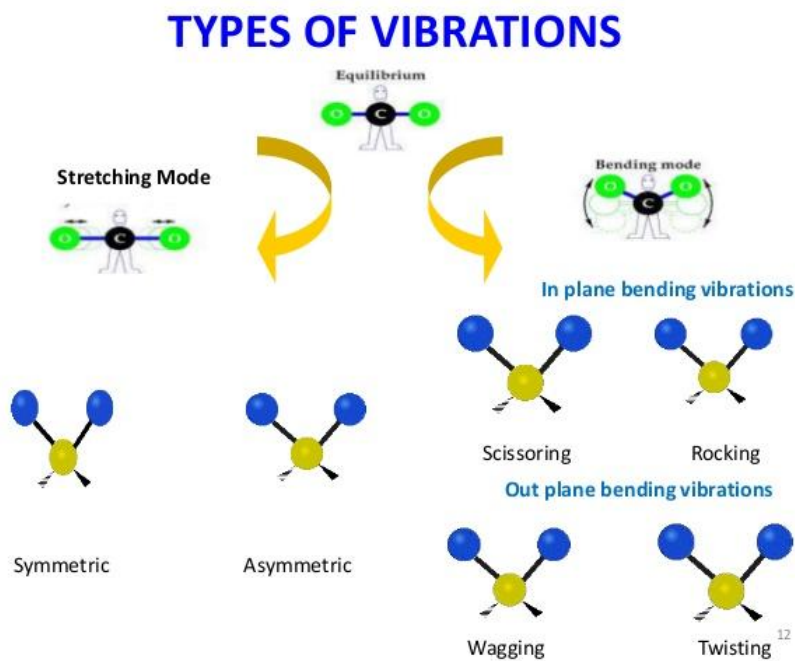

### Absorption bands

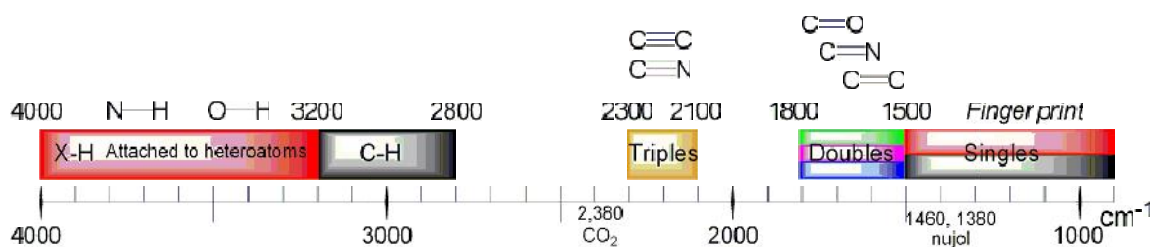

**Fourier transform infrared (FTIR)** spectroscopy is a measurement technique that allows one to record infrared spectra. Infrared light is guided through an interferometer and then through the sample (or vice versa). A moving mirror inside the apparatus alters the distribution of infrared light that passes through the interferometer. The signal directly recorded, called an "interferogram", represents light output as a function of mirror position. A data-processing technique called Fourier transform turns this raw data into the desired result (the sample's spectrum): Light output as a function of infrared

wavelength (or equivalently, wave number). The sample's spectrum is always compared to that of the spectrum of the reference.

## **APPLICATIONS:**

Infrared spectroscopy is widely used in industry as well as in research. It is a simple and reliable technique for measurement, quality control and dynamic measurement. It is also employed in forensic analysis in civil and criminal analysis.

### **1. Identification of functional group and structure elucidation**

Entire IR region is divided into group frequency region and fingerprint region. Range of group frequency is  $4000-1500\text{ cm}^{-1}$  while that of finger print region is  $1500-400\text{ cm}^{-1}$ . In group frequency region, the peaks corresponding to different functional groups can be observed. According to corresponding peaks, functional group can be determined. Each atom of the molecule is connected by bond and each bond requires different IR region so characteristic peaks are observed. This region of IR spectrum is called as finger print region of the molecule. It can be determined by characteristic peaks.

### **2. Identification of substances**

IR spectroscopy is used to establish whether a given sample of an organic substance is identical with another or not. This is because large number of absorption bands is observed in the IR spectra of organic molecules and the probability that any two compounds will produce identical spectra is almost zero. So if two compounds have identical IR spectra then both of them must be samples of the same substances.

### **3. Studying the progress of the reaction**

Progress of chemical reaction can be determined by examining the small portion of the reaction mixture withdrawn from time to time. The rate of disappearance of a



characteristic absorption band of the reactant group and/or the rate of appearance of the characteristic absorption band of the product group due to formation of product is observed.

#### **4. Detection of impurities**

IR spectrum of the test sample to be determined is compared with the standard compound. If any additional peaks are observed in the IR spectrum, then it is due to impurities present in the compound.

#### **5. Quantitative analysis**

The quantity of the substance can be determined either in pure form or as a mixture of two or more compounds. In this, characteristic peak corresponding to the drug substance is chosen and peaks for standard and test sample are compared rationally. This is called base line technique to determine the quantity of a substance.

#### ***NUCLEAR MAGNETIC RESONANCE SPECTROSCOPY (NMR):***

Nuclear Magnetic Resonance (NMR) Spectroscopy is a non-destructive analytical technique that is used to probe the nature and characteristics of molecular structure. A simple NMR experiment produces information in the form of a spectrum, which is able to provide details about:

- The types of atoms present in the sample
- The relative amounts of atoms present in a sample
- The specific environments of atoms within a molecule
- The purity and composition of a sample
- Structural information about a molecule, including constitutional and conformational isomerization.

There are a number of important characteristics of NMR spectroscopy which makes it favourable to a wide array of industrial, commercial and research applications. There are many nuclei which are NMR active. Some of the more common NMR active nuclei include  $^1\text{H}$ ,  $^2\text{H}$ ,  $^{13}\text{C}$ ,  $^{11}\text{B}$ ,  $^{15}\text{N}$ ,  $^{19}\text{F}$ ,  $^{31}\text{P}$  and  $^{195}\text{Pt}$ . NMR spectroscopy is generally a non-destructive technique, meaning that samples can be recovered. Only a small quantity of material is required for analysis; sample sizes of 5-20mg are generally sufficient for most NMR experiments. Sample preparation is simple and minimal. Typically, samples are simply dissolved in an appropriate solvent.

Today, NMR has become a sophisticated and powerful analytical technology that has found a variety of applications in many disciplines of scientific research, medicine, and various industries. Modern NMR spectroscopy has been emphasizing the application in biomolecular systems and plays an important role in structural biology. With developments in both methodology and instrumentation in the past two decades, NMR has become one of the most powerful and versatile spectroscopic techniques for the analysis of biomacromolecules, allowing characterization of biomacromolecules and their complexes up to 100 kDa.

Together with X-ray crystallography, NMR spectroscopy is one of the two leading technologies for the structure determination of biomacromolecules at atomic resolution. In addition, NMR provides unique and important molecular motional and interaction profiles containing pivotal information on protein function. The information is also critical in drug development.

### **Principle:**

The principle behind NMR is that many nuclei have spin and all nuclei are electrically charged. If an external magnetic field is applied, an energy transfer is possible between the base energy to a higher energy level (generally a single energy gap). The energy transfer takes place at a wavelength that corresponds to radio frequencies and when the spin returns to its base level, energy is emitted at the same frequency. The signal that

matches this transfer is measured in many ways and processed in order to yield an NMR spectrum for the nucleus concerned.

Nuclear magnetic resonance provides detailed information about the structure, dynamics, reaction state, and chemical environment of molecules.

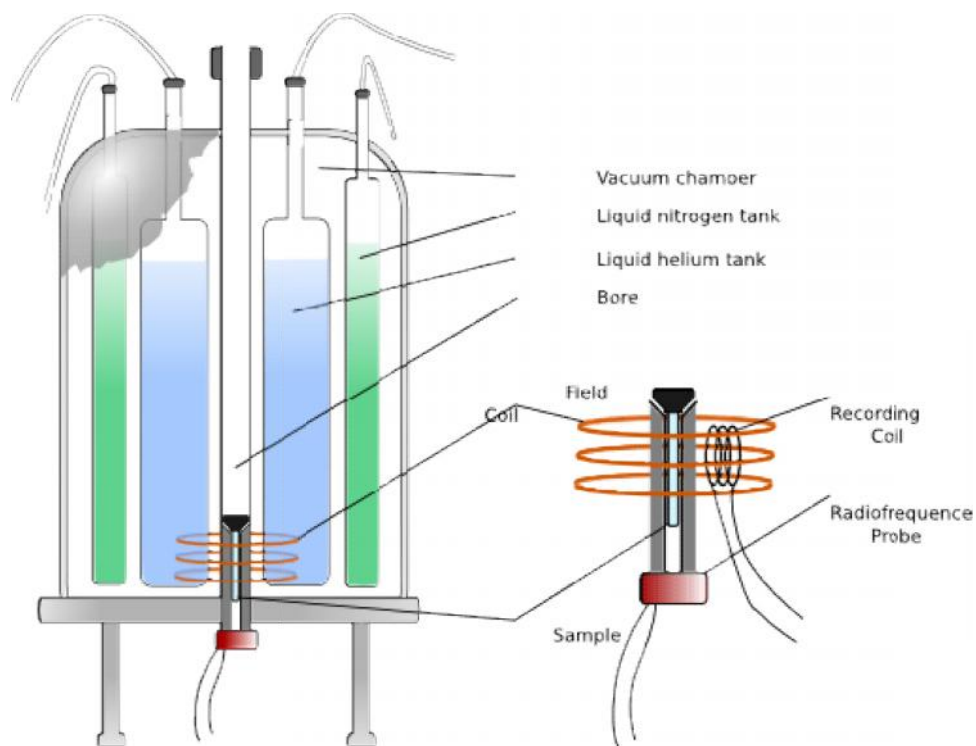

### **APPLICATIONS:**

NMR Spectroscopy is a technique used by most modern chemical laboratories. It has applications in a wide range of disciplines, and development of new applied methods for NMR is an active area of research. Methods in NMR spectroscopy have particular relevance to the following disciplines:

Chemical research and development: organic, inorganic and physical chemistry

Chemical manufacturing industry

Biological and biochemical research

Food industry

Pharmaceutical development and production

Agrochemical development and production

Polymer industry

**Common applications of NMR Spectroscopy include:**

Structure elucidation

Chemical composition determination

Formulations investigation

Raw materials fingerprinting

Mixture analysis

Sample purity determination

Quality assurance and control

Quantitative analysis

Compound identification and confirmation

Analysis of inter- and intramolecular exchange processes

Molecular characterisation

Reaction kinetics examination

Hydrogen bonding

Reaction mechanism investigation

**MASS SPECTROSCOPY (MS):**

Mass spectrometry is a powerful analytical technique used to quantify known materials, to identify unknown compounds within a sample, and to elucidate the structure and chemical properties of different molecules. The complete process involves the conversion of the sample into gaseous ions, with or without fragmentation, which are then characterized by their mass to charge ratios ( $m/z$ ) and relative abundances.

This technique basically studies the effect of ionizing energy on molecules. It depends upon chemical reactions in the gas phase in which sample molecules are consumed during the formation of ionic and neutral species.

### Principle:

A mass spectrometer generates multiple ions from the sample under investigation, it then separates them according to their specific mass-to-charge ratio ( $m/z$ ), and then records the relative abundance of each ion type.

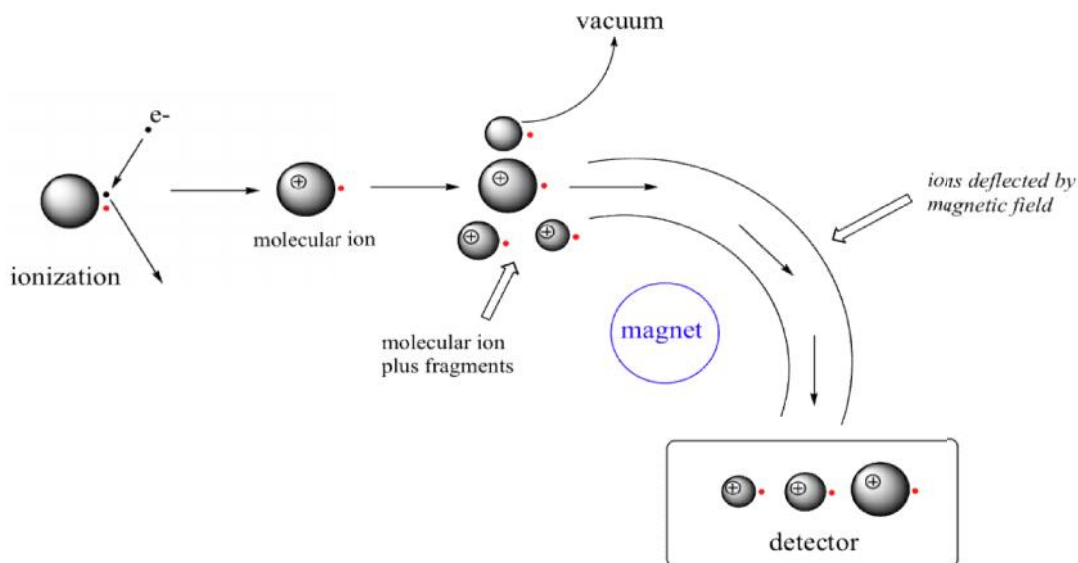

The first step in the mass spectrometric analysis of compounds is the production of gas phase ions of the compound, basically by electron ionization. This molecular ion undergoes fragmentation. Each primary product ion derived from the molecular ion, in turn, undergoes fragmentation, and so on. The ions are separated in the mass spectrometer according to their mass-to-charge ratio, and are detected in proportion to their abundance.

A mass spectrum of the molecule is thus produced. It displays the result in the form of a plot of ion abundance versus mass-to-charge ratio. Ions provide information concerning the nature and the structure of their precursor molecule. In the spectrum of a pure compound, the molecular ion, if present, appears at the highest value of  $m/z$  (followed by ions containing heavier isotopes) and gives the molecular mass of the compound.



MS is an analytical technique used to determine the elemental composition of a sample or molecule, and for elucidating the chemical structures of molecules, such as peptides and other chemical compounds. MS works by ionizing chemical compounds to generate charged molecules or molecule fragments and measuring their mass-to-charge ratios. In a typical MS procedure:

A sample is loaded onto the mass spectrometer, and undergoes vaporization. The components of the sample are ionized by one of a variety of methods (e.g., by impacting them with an electron beam), which results in the formation of charged particles (ions). The ions are separated according to their mass-to-charge ratio in an analyzer by electromagnetic fields. The ions are detected, usually by a quantitative method. The ion signal is processed into mass spectra. The different components of a Mass Spectrometer are given in the following diagram-

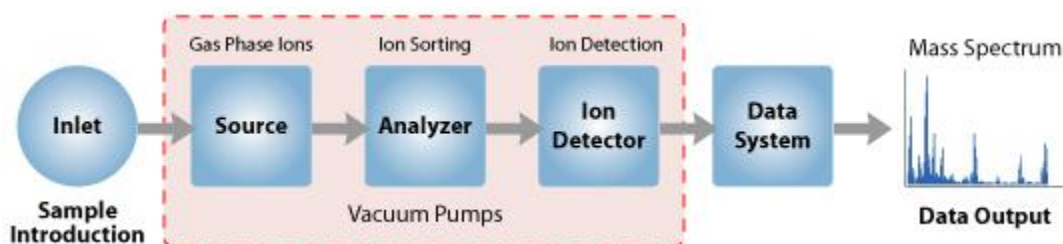

## **APPLICATIONS:**

Mass spectrometry is fast becoming an indispensable field for analyzing drugs, chemical compounds and biomolecules. The development of desorption ionization methods based on the emission of pre-existing ions such as plasma desorption (PD), fast atom bombardment (FAB) or laser desorption (LD), allowed the application of mass spectrometry for analyzing complex biomolecules.

### **1. Analysis of Glycans**

Oligosaccharides are molecules formed by the association of several monosaccharides linked through glycosidic bonds. The determination of the complete structure of oligosaccharides is more complex than that of proteins or oligonucleotides. It involves the determination of additional components as a consequence of the isomeric nature of monosaccharides and their capacity to form linear or branched oligosaccharides. Knowing the structure of an oligosaccharide requires not only the determination of its monosaccharide sequence and its branching pattern, but also the isomer position and the anomeric configuration of each of its glycosidic bonds.

Advances in glycobiology involves a comprehensive study of structure, bio-synthesis, and biology of sugars and saccharides. Mass spectrometry (MS) is emerging as an enabling technology in the field of glycomics and glycobiology.

### **2. Analysis of Lipids**

Lipids are made up of many classes of different molecules which are soluble in organic solvents. Lipidomics, a major part of metabolomics, constitutes the detailed analysis and global characterization, both spatial and temporal, of the structure and function of lipids (the lipidome) within a living system.

Many new strategies for mass-spectrometry-based analyses of lipids have been developed. The most popular lipidomics methodologies involve electrospray ionization (ESI) sources and triple quadrupole analyzers. Using mass spectrometry, it is possible to determine the molecular weight, elemental composition, the position of branching and nature of substituents in the lipid structure.

### **3. Analysis of Proteins and Peptides**

Proteins and peptides are linear polymers made up of combinations of the 20 amino acids linked by peptide bonds. Proteins undergo several post translational modifications, extending the range of their function via such modifications.

The term Proteomics refers to the analysis of complete protein content in a living system, including co- and post-translationally modified proteins and alternatively spliced variants. Mass Spectrometry has now become a crucial technique for almost all proteomics experiments. It allows precise determination of the molecular mass of peptides as well as their sequences. This information can very well be used for protein identification, de novo sequencing, and identification of post-translational modifications.

### **4. Analysis of Oligonucleotides**

Oligonucleotides (DNA or RNA), are linear polymers of nucleotides. These are composed of a nitrogenous base, a ribose sugar and a phosphate group. Oligonucleotides may undergo several natural covalent modifications which are commonly present in tRNA and rRNA, or unnatural ones resulting from reactions with exogenous compounds. Mass spectrometry plays an important role in identifying these modifications and determining their structure as well as their position in the oligonucleotide. It not only allows determination of the molecular weight of oligonucleotides, but also in a direct or indirect manner, the determination of their sequences.



## CHROMATOGRAPHY:

Chromatography is the collective term for a set of laboratory techniques for the separation of mixtures. The mixture is dissolved in a fluid called the mobile phase, which carries it through a structure holding another material called the stationary phase. The various constituents of the mixture travel at different speeds, causing them to separate. The separation is based on differential partitioning between the mobile and stationary phases. Subtle differences in a compound's partition coefficient result in differential retention on the stationary phase and thus changing the separation.

**THIN LAYER CHROMATOGRAPHY (TLC):** is a chromatography technique used to separate mixtures. Thin layer chromatography is performed on a sheet of glass, plastic, or aluminum foil, which is coated with a thin layer of adsorbent material, usually silica gel, aluminium oxide, or cellulose (blotter paper). This layer of adsorbent is known as the stationary phase.

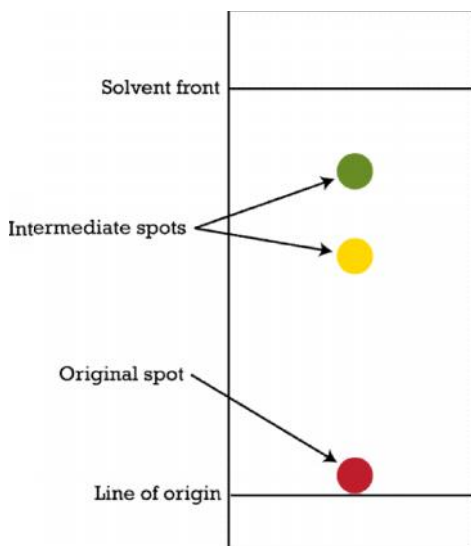

## COULMN CHROMATOGRAPHY:

It is a method used to purify individual chemical compounds from mixtures of compounds. It is often used for preparative applications on scales from micrograms up to

kilograms. The main advantage of column chromatography is the relatively low cost and disposability of the stationary phase used in the process. The latter prevents cross-contamination and stationary phase degradation due to recycling.

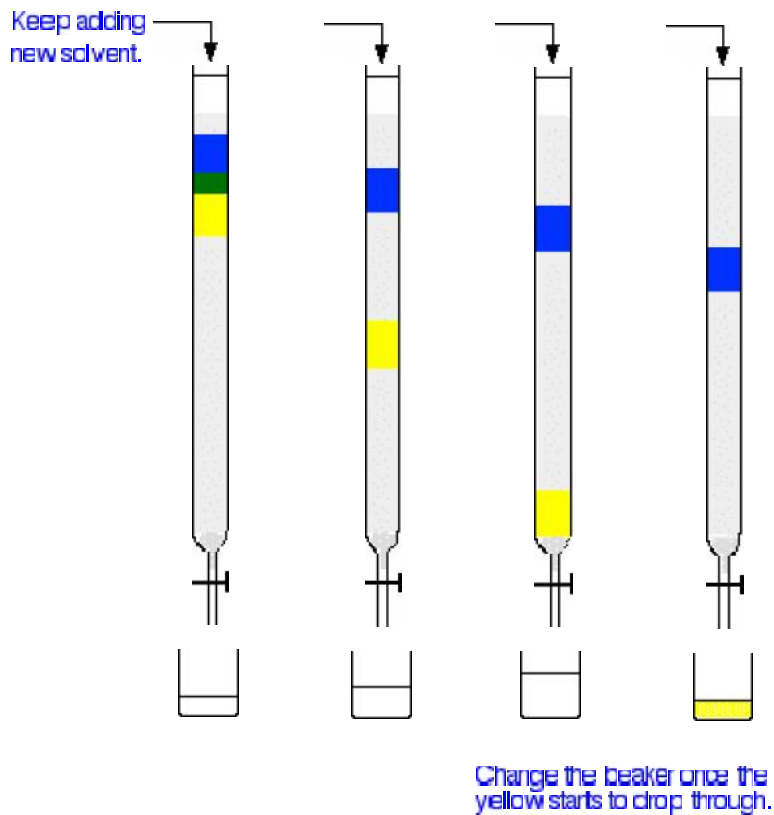

The classical preparative chromatography column, is a glass tube with a diameter from 5 mm to 50 mm and a height of 5 cm to 1 m with a tap and some kind of a filter (a glass frit or glass wool plug – to prevent the loss of the stationary phase) at the bottom. Two methods are generally used to prepare a column: the dry method, and the wet method.

## 8. CALIBRATION OF UV-SPECTROPHOTOMETER

Molecular absorption spectroscopy in the ultraviolet and visible spectral regions is widely used for the quantitative determination of a large number of inorganic, organic, and biological species.

The molecular absorption is studied in the wavelength region of 190 to 800 nm of electromagnetic spectrum. The following diagram shows the visible range in electromagnetic spectrum-

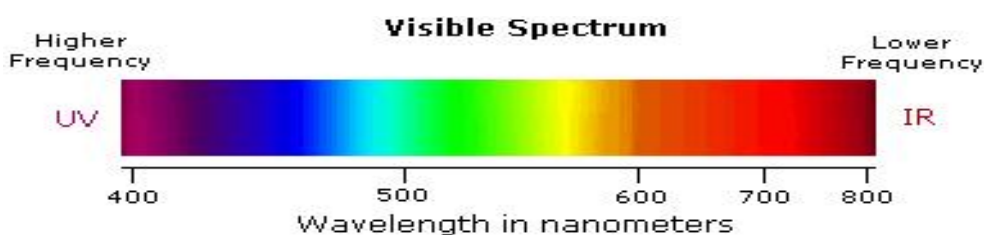

- Violet: 400 - 420 nm
- Indigo: 420 - 440 nm
- Blue: 440 - 490 nm
- Green: 490 - 570 nm
- Yellow: 570 - 585 nm
- Orange: 585 - 620 nm
- Red: 620 - 780 nm

### Principle:

Molecular absorption spectroscopy is based on the measurement of transmittance  $T$  or the absorbance  $A$  of solutions contained in transparent cells having a path length of  $b$  centimeters. Ordinarily, the concentration of an absorbing analyte is linearly related to absorbance as given by Beer's Law:

$$A = -\log T = \log p / \log p = ebc$$

Where,  $p$  = incident radiant power,  $b$  = path length of sample,  $c$  = concentration of absorber,  $e$  = molar absorptivity,  $p$  = transmitted radiant power,  $A$  = absorbance,  $T$  = transmittance.

### Beer-Lambert Law:

The Beer Lambert Law states that the concentration of a substance in solution is directly proportional to the absorbance 'A' of the solution.

$$A = \text{Constant} \times \text{concentration} \times \text{cell length}$$

The law is only true for monochromatic light that is light of a single wave length or narrow band of wave length, and provided that the physical or chemical state of the substance does not change with the concentration.

When monochromatic radiation passes through a homogeneous solution in a cell, the intensity of the emitted radiation depends upon the thickness 'l' and the concentration 'C' of the solution.

$$A = \log_{10} I_0/I$$

$I_0$  is the intensity of incident radiation and  $I$  is the intensity of transmitted radiation. The ratio  $I/I_0$  is called transmittance. This is sometimes expressed as a percentage and referred to as percentage transmittance.

Following diagram shows different component of an UV spectrometer-

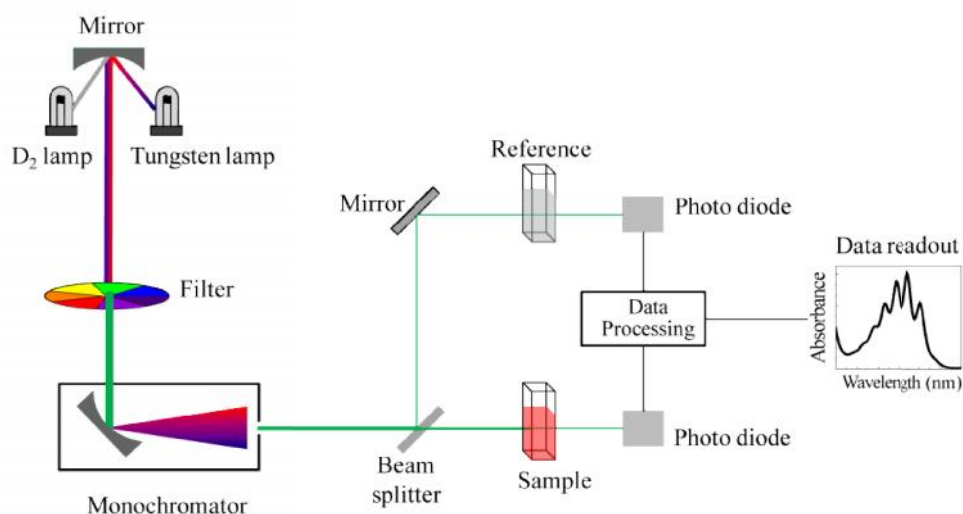

**Procedure:**

**Preparation of solution of potassium dichromate UV:** Prepare potassium dichromate solution previously dried to a constant weight at 130 °C (6.006 For the control of the absorbance at 235 nm, 257 nm, 313 mg/100 ml in 0.005 N sulphuric acid). It exhibits characteristic spectral graph having minimum (valley) at 235 and 313 nm and maxima at 257 and 350 nm. Potassium dichromate is a notorious oxidizing agent resulting in very poor stability of the solution in addition to resulting process errors that arise from making up the solution.

**Absorbance accuracy of UV-visible spectrophotometers using potassium dichromate solution in 0.005 N sulphuric acid.**

Wavelength (nm)	Absorbance
235 nm( minima/valley)	0.748 (0.740-0.756)
257 nm (maxima)	0.865 (0.856-0.894)
313 nm (Minima/valley)	0.292 (0.289-0.295)
350 nm (maxima)	0.640 (0.6340.646)

**Limit of stray light:** Stray light may be detected at a given wavelength with suitable filters or solutions; for example, absorbance of a 1.2% w/v solution of potassium chloride in a 1 cm cell should be greater than 2.0 at about 200 nm when compared with water as reference liquid.

**Preparation of 0.005 M sulphuric acid:** 0.03 ml of sulphuric acid is dissolved in 1000 ml distilled water.



## 9. PREPARATION OF CALIBRATION CURVE OF CIPROFLOXACIN

Ciprofloxacin is an antibiotic in a group of drugs called fluoroquinolones. Ciprofloxacin fights bacteria in the body. Ciprofloxacin is used to treat different types of bacterial infections. It is a faintly yellowish to light yellow crystalline substance with a molecular weight of 385.8. It is used orally, 250 to 750 mg twice daily, by intravenous infusion, 100 mg to 200 mg twice daily.

### Molecular formula:

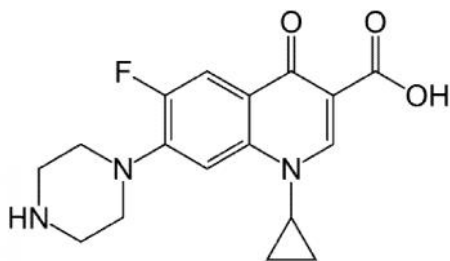
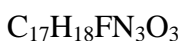

1-cyclopropyl-6-fluoro-1,4-dihydro-4-oxo-7-(piperazin-1-yl)quinoline-3-carboxylic acid

Ciprofloxacin is 1-cyclopropyl-6-fluoro-1,4-dihydro-4-oxo-7-(1-piperazinyl)-3-quinolinecarboxylic acid. Ciprofloxacin hydrochloride is the monohydrochloride monohydrate salt of ciprofloxacin. It is a faintly yellowish to light yellow crystalline substance.

### Validation of the method:

#### 1. Reproducibility:

Reproducibility of the method is studied by analyzing six individually weighed samples of ciprofloxacin HCl. The present relative standard deviation (RSD) of the determination is found to be less than 1.0%.

## **2. Interference Study:**

The interference in the method by the Indion 414, Indion 254, stearic acid, PEG 1500 and other materials used in the present investigation is studied by testing their effects individually. Accurately weighed amounts of ciprofloxacin HCl and Indion 414, Indion 254, stearic acid, PEG 1500 and other materials in 1:1 ratio are mixed thoroughly. From each mixture, an accurately weighed powder equivalent to 100 mg of ciprofloxacin HCl is assayed using UV-spectrophotometer. The ciprofloxacin HCl contents are calculated using the calibration curve.

**Solubility:** Sparingly soluble in 0.1M hydrochloric acid and in glacial acetic acid.

### **Procedure:**

#### **Preparation of standard solution:**

Weigh accurately about 100 mg ciprofloxacin in a 100 ml volumetric flask. Dissolve it in 60-70 ml of 0.1N hydrochloric acid, shake for 10 min and make up to 100 ml. Pipette out 1ml of this standard stock solution to a 10 ml volumetric flask and make up the volume to the mark with 0.1 N hydrochloric acid.

From this stock solution, take 5.0 ml in a 50 ml volumetric flask, add 1 ml of freshly prepared 1% w/v ferric chloride solution and make up the volume to the mark with 0.1N hydrochloric acid, and prepare 2, 4, 6, 8, 10 mcg solution and measure the absorption of the solution at a maximum (  $\lambda_{max}$ ) at about 438 nm against reagent blank (1 ml of ferric chloride solution diluted to 50 ml with acid).



## 10. ASSAY OF CIPROFLOXACIN TABLET/CAPSULE

Assay of ciprofloxacin tablet/capsule is done by UV-visible spectrophotometry. Other methods are also applied but UV-method is easy and cheaper.

The structure and theory involved in the assay is provided in the previous experiment.

### Procedure:

#### a) Preparation of standard solution:

Weigh accurately about 250 mg ciprofloxacin in a 250 ml volumetric flask. Dissolved it in 60-70 ml of 0.1N hydrochloric acid and make the volume upto the mark. Pipette out 1 ml of this standard stock solution to a 10 ml volumetric flask and make the volume upto the mark by 0.1 N hydrochloric acid.

#### b) Preparation of sample solution:

Weigh accurately powdered sample equivalent to 250 mg of the substance (Ciprofloxacin), added 60-70 ml of 0.1N hydrochloric acid, shake for 10 minutes and made upto 250 ml with the 0.1N hydrochloric acid.

From this solution, take 1.0 ml in a 10 ml volumetric flask. To it add 0.2 ml freshly prepared 1% w/v ferric chloride solution and make the volume up to the mark with 0.1N hydrochloric acid and measure the absorption of the solution at a maximum ( max) at about 438nm on a UV-spectrometer against reagent blank (1 ml of ferric chloride solution diluted to 50ml with acid) .

$$\% \text{ assay} = \frac{\text{Abs of sample}}{\text{Abs of standard}} \times \frac{\text{Wt. of Std}}{\text{Dillution Factor}} \times \frac{\text{Dillution Factor}}{\text{Wt. of sample}} \times \frac{\text{Avg. Wt. of 20 Tablet}}{\text{Label claim}} \times 100$$

## 11. PREPARATION OF CALIBRATION CURVE OF METFORMIN

Metformin hydrochloride is a biguanide class of antidiabetic drug, chemically is *N,N*-dimethyl-imido-dicarbonimidic diamide hydrochloride. The anti-diabetic Metformin hydrochloride indicated for the relief of signs and symptoms of Type-2 diabetes mellitus or non-insulin dependent diabetes mellitus (NIDDM), and hyperglycemia. It is also used in the treatment of polycystic ovary syndrome.

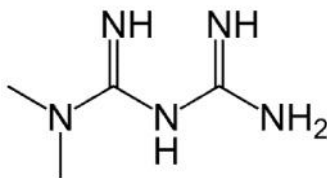

Metformin

**Molecular formula:** C<sub>4</sub>H<sub>11</sub>N<sub>5</sub>

### **Procedure:**

#### **a) Preparation of standard solution:**

Weigh accurately about 50 mg Metformin HCl in a 50 ml volumetric flask and make upto the mark. With distill water and prepare 2, 4, 6, 8, 10 mcg solution by stock solution and take absorption at 232 nm ( max) on a UV-spectrometer. Plot graph absorption vs concentration, this is standard plot. By extrapolating the prepared graph with the absorption of sample, the concentration may be calculated.

## 12. ASSAY OF METFORMIN TABLET/CAPSULE

The assay of Metformin tablet/capsule is performed using UV-visible spectrophotometry.

The structure and theory involved in the assay is provided in the previous experiment.

### Procedure:

#### a) Preparation of standard solution:

Weigh accurately about 50 mg Metformin in a 50 ml volumetric flask and dissolved in dist. water. From this stock solution prepare 5 mcg test solution.

#### b) Preparation of sample solution:

Weigh accurately powdered sample equivalent to 50mg of the substance (Metformin) Metformin in a 50ml volumetric flask and dissolved in dist. water. From this stock solution prepare 5 mcg test solution and determine absorption at 232 nm ( max) on a UV-spectrometer.

$$\% \text{ assay} = \frac{\text{Abs of sample}}{\text{Abs of standard}} \times \frac{\text{Wt. of Std}}{\text{Dillution Factor}} \times \frac{\text{Dillution Factor}}{\text{Wt. of sample}} \times \frac{\text{Avg. Wt. of 20 Tablet}}{\text{Label claim}} \times 100$$

### 13. ASSAY OF RIFAMPICIN TABLET/CAPSULE

**Rifampicin**, also known as **rifampin**, is an antibiotic used to treat a number of bacterial infections. This includes tuberculosis, leprosy, and legionella, etc. Often it is used along with other antibiotics. It is also used to prevent *Haemophilus influenzae type b* and meningococcal infections.

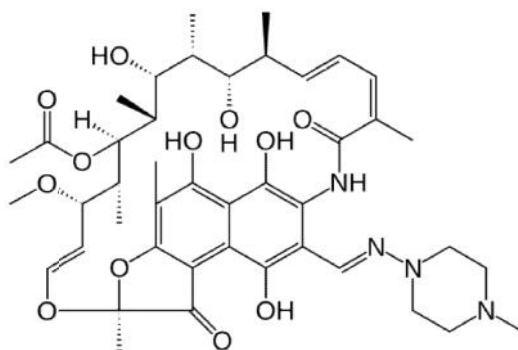

Rifampicin

Assay of rifampicin tablet/capsule is done by UV-visible spectrophotometry. Other methods are also applied but UV-method is easy and cheaper.

#### Procedure:

**a) Preparation of standard solution:** Prepare 1 mg/ml of Rifampicin in methanol as a standard solution of rifampicin.

**b) Preparation of sample solution:** Weigh accurately the sample equivalent to about 100 mg of the rifampicin, add 50 ml of methyl alcohol, shake and make the volume up to 100 ml with methanol.

## Procedure:

### Method 1:

Take 5 ml each of potassium dichromate solution and buffer solution in two flasks. Add 2 ml each of sample and standard solutions. Stir well and after 1 minute, extract with two 10 ml portions of methyl isobutyl ketone. Make up the volume to 25 ml with the solvent. Measure the absorption of resulting solution at about 540 nm ( max) against reagent blank. Deduce the results by comparison.

### Method 2:

Prepare solution of sample in methanol (1mg/ml). further dilution is done with pH 7.4 buffer (prepared as per IP 1996) to get final concentration of 20 mcg/ml. measure the extinction at about 475nm ( max) and calculate the taking 187 as the value of A 1%,1cm at 475nm ( max).

Phosphate buffer (pH 7.4): Weigh about 2.38 gm of  $\text{Na}_2\text{HPO}_4$ , 8.0 gm of NaCl and 0.19 gm of  $\text{KH}_2\text{PO}_4$ . Dissolve in 250 ml of water and dilute upto 1.0 L with water. Maintain the pH to 7.4.

Preparation of phosphate buffer: Weigh 6.804 g of potassium dihydrogen phosphate with 195.5ml of 0.2M sodium hydroxide and volume is made upto 1000 ml with distilled water.

$$\% \text{ assay} = \frac{\text{Abs of sample}}{\text{Abs of standard}} \times \frac{\text{Wt. of Std}}{\text{Dillution Factor}} \times \frac{\text{Dillution Factor}}{\text{Wt. of sample}} \times \frac{\text{Avg. Wt. of 20 Tablet}}{\text{Label claim}} \times 100$$

## 14. INTERPRETATION OF THE IR SPECTRA OF ETHANOL, ACETONE AND FORMALDEHYDE

Infrared spectroscopy (IR spectroscopy) is the spectroscopy that deals with the infrared region of the electromagnetic spectrum. As with all spectroscopic techniques, it can be used to identify and study chemicals. A common laboratory instrument that uses this technique is a Fourier transform infrared (FTIR) spectrometer.

The infrared portion of the electromagnetic spectrum is usually divided into three regions; the near-, mid- and far- infrared, named for their relation to the visible spectrum. The higher-energy near-IR, approximately  $14000\text{--}4000\text{ cm}^{-1}$  ( $0.8\text{--}2.5\text{ }\mu\text{m}$  wavelength) can excite overtone or harmonic vibrations. The mid-infrared, approximately  $4000\text{--}400\text{ cm}^{-1}$  ( $2.5\text{--}25\text{ }\mu\text{m}$ ) may be used to study the fundamental vibrations and associated rotational-vibrational structure. The far-infrared, approximately  $400\text{--}10\text{ cm}^{-1}$  ( $25\text{--}1000\text{ }\mu\text{m}$ ), lying adjacent to the microwave region, has low energy and may be used for rotational spectroscopy.

### Procedure:

1. Take dry potassium bromide (KBr), or dry it at  $100\text{--}120\text{ }^{\circ}\text{C}$  to make it free from moisture.
2. Prepare KBr pellet using manual or automatic hydraulic press (KBr press).
3. Mix KBr with the standard compound/drug properly in a ratio of 99:1, and prepare pellets by KBr press.
4. Record standard spectrum by FTIR.
5. Mix KBr with the given sample compound/drug in a ratio of 99:1 and prepare pellets by KBr Press.
6. Record spectrum by FTIR and compare it with standard and interpret.

Following peaks should be obtained in the spectra of ethanol, acetone and formaldehyde-

**Standard spectrum of ethanol C<sub>2</sub>H<sub>5</sub>OH:**

S. No.	Peak (signal)	Vibration
1.	3342 cm <sup>-1</sup>	O-H Stretch
2.	1330 cm <sup>-1</sup>	O-H in plane bend
3.	1050 cm <sup>-1</sup>	C-C-O asymmetric stretch
4.	881 cm <sup>-1</sup>	C-C-O symmetric stretch
5.	667 cm <sup>-1</sup>	O-H out of plane bend

**Standard spectrum of Acetone CH<sub>3</sub>COCH<sub>3</sub>:**

S. No.	Peak (signal)	Vibration
1.	1715 cm <sup>-1</sup>	C=O Stretch
2.	1222 cm <sup>-1</sup>	C-C-C Stretch

**Standard spectrum of Formaldehyde HCHO:**

S. No.	Peak (signal)	Vibration
1.	1735 cm <sup>-1</sup>	Saturated C=O Stretch
2.	1785 cm <sup>-1</sup>	Aromatic C=O stretch
3.	1390 cm <sup>-1</sup>	C-H bend
4.	2850-2700cm <sup>-1</sup> (1 or 2 bands)	Aldehydic C-H stretch, general
5.	2730 cm <sup>-1</sup>	Aldehydic C-H stretch, unbranched carbon
6.	2715 cm <sup>-1</sup>	Aldehydic C-H stretch, branched carbon

## 15. INTERPRETATION OF THE IR SPECTRA OF ASPIRIN

Aspirin (acetyl salicylic acid),  $C_6H_8O_4$

Aspirin is used as analgesic, antipyretic, anti-inflammatory, blood thinning agent, etc. It may be identified by its IR spectrum.

The theory, principle and applications have been discussed earlier.

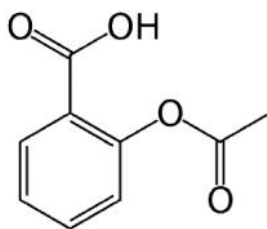

Aspirin

### Procedure:

1. Take dry potassium bromide (KBr), or dry it at 100-120 °C to make it free from moisture.
2. Prepare KBr pellet using manual or automatic hydraulic press (KBr press).
3. Mix KBr with the standard aspirin drug properly in a ratio of 99:1, and prepare pellets by KBr press.
4. Record standard spectrum by FTIR.
5. Mix KBr with the given sample of aspirin in a ratio of 99:1 and prepare pellets by KBr Press.
6. Record spectrum by FTIR and compare it with standard and interpret.

Following peaks should be obtained in the spectra of aspirin-



### Standard spectrum of aspirin:

S. No.	Peak (signal)	Vibration
1.	3500-2500 $\text{cm}^{-1}$	Acid O-H stretch
2.	3064 $\text{cm}^{-1}$	Aromatic C-H stretch
3.	1753 $\text{cm}^{-1}$	C=O stretch (saturated)
4.	1691 $\text{cm}^{-1}$	C=O stretch (Aromatic)
5.	1604,1595 $\text{cm}^{-1}$	Aromatic ring modes
6.	1418 $\text{cm}^{-1}$	Acid in plane O-H bends
7.	1369 $\text{cm}^{-1}$	Methyl Umbrella mode
8.	1305 $\text{cm}^{-1}$	Acid C-O stretch
9.	1188 $\text{cm}^{-1}$	Saturated ester C-C-O
10.	1094 $\text{cm}^{-1}$	Saturated ester O-C-C
11.	917 $\text{cm}^{-1}$	Acid out of plane OH- Bend
12.	755 $\text{cm}^{-1}$	Aromatic out of plane C-H bend

## 16. STUDY OF WORKING OF HPLC INSTRUMENT

High-performance liquid chromatography (HPLC) is a separation technique that can be used for the analysis of organic molecules and ion. HPLC is based on mechanism of adsorption, partition, ion exchange or size exclusion, depending on the type of stationary phase used. HPLC involve a solid stationary phase, normally packed inside a stainless steel column, and a liquid mobile phase. Separation of the component of a solution results from the difference in the relative distribution ratios of the solutes between the two phases.

HPLC can be used to access the purity and/or and determine the content of many pharmaceutical substances. It can also be used to determine enantiomeric composition, using suitably modified mobile phase or chiral stationary phases. Individual separation mechanism of adsorption, partition, ion exchange and size exclusion rarely occur in isolation, since several principle act to a certain degree simultaneously.

### INSTRUMENTATION:

The apparatus consist of a pumping system, an injector, a chromatographic column, stationary and mobile phases, connecting tubing and fittings, a detector, and a data collecting device (computer, integrator or recorder).

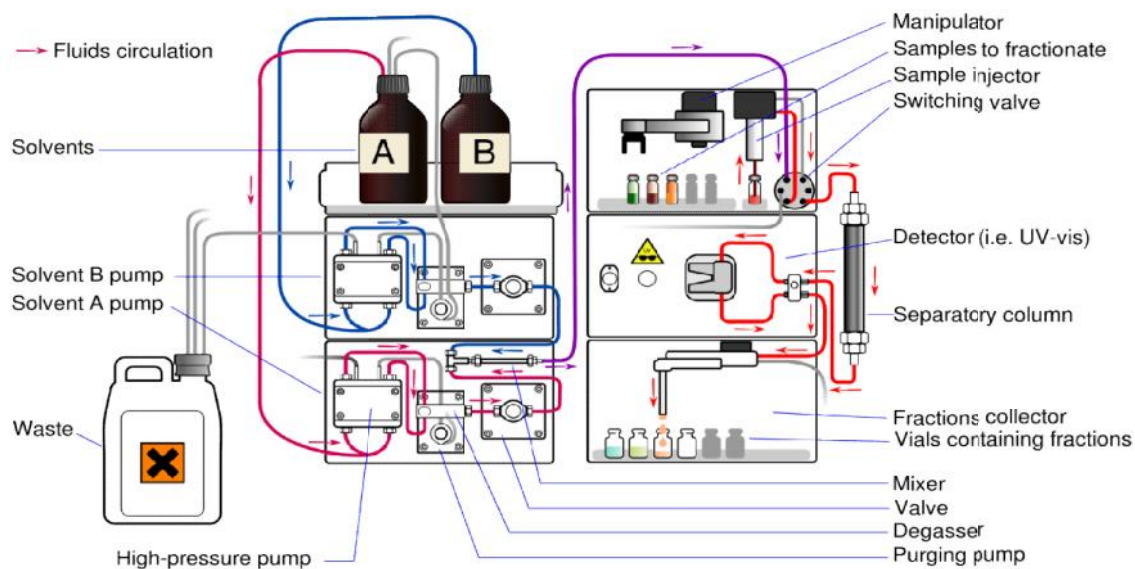

## Pumping system

HPLC pumping systems are required to deliver metered amount of mobile phase at a constant flow rate. Pumping system that deliver solvent from one or more reservoir are available. Pressure fluctuation can be minimized e.g. by passing the pressurized solvent through a pulse-dampening device. Tubing and connection should be capable of withstanding the pressure developed by the pumping system. Many HPLC pumps are fitted with a facility for “bleeding” the system of entrapped air bubbles.

## Injector

The sample solution is usually introduced into the following mobile phase at or near the head of the column using an injector system based on an injection valve design which can operate at high pressure. Such an injector system has a fixed loop or a variable volume device which can be operated manually or by an auto-sampler. Partial filling of a loop may lead to poorer injection volume precision.

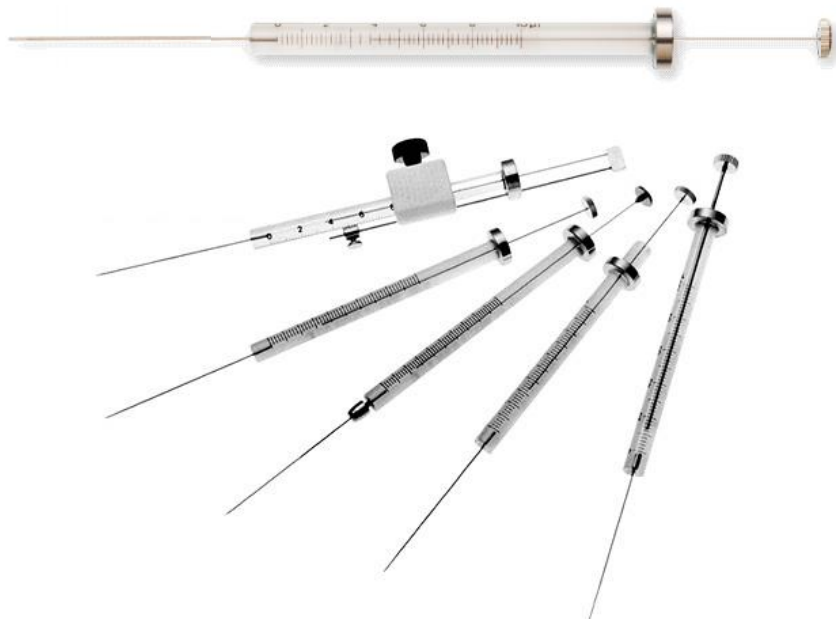

## Chromatographic column

Columns are usually made of polished stainless steel, are between 50 and 300mm long, and have an internal diameter of between 2 and 5mm. they are commonly filled with a stationary phase with a particle size of 5-10 $\mu$ m. columns with internal diameter of less than 2mm are often referred to as micropore columns. Ideally, the temperature of the mobile phase and the column should be kept constant during an analysis. Most separation are performed at ambient temperature but column may be heated using, for instance, Normally, column should not be heated above 60 °C because of the potential for stationary phase degradation or change occurring to the composition of the mobile phase.



## Stationary phase

Separation of pharmaceuticals is usually achieved by partition of compounds in the test solution between the mobile and the stationary phase. HPLC system consisting of polar stationary phase and non polar mobile phase are described as normal phase chromatography; those with nonpolar stationary phase and polar mobile phases are called reverse-phase chromatography.

There are many types of stationary phases including:

- Unmodified silica, alumina, or porous graphite, used in normal-phase chromatography, when separation is based on differences in absorption;
- A variety of chemically modified supports prepared from polymers, silica, or porous graphite, used in reverse-phase HPLC. Where separation is based principally on partition of the molecule between the mobile phase and the stationary phase;
- Resin or polymer

with acidic or basic group, used in ion-exchange chromatography, where separation is based on competition between the ion to be separated and those in the mobile phase;

- Porous silica or polymer, used in size-exclusion chromatography, where separation is based on the relative molecular mass of the molecules.

Most separations are based on partition mechanism using chemically modified silica as the stationary phase and polar solvent as the mobile phase (reverse-phase HPLC). The surface of the support, e.g. the silanol group of silica, is reacted with various silane reagents to produce covalently bonded silyl derivative covering a varying number of active sites on the surface of the support. The nature of the bonded phase is an important parameter for determining the separation properties of the chromatographic system.

Commonly used bonded phase are as follows-

Octyl	Si-(CH <sub>2</sub> ) <sub>7</sub> -CH <sub>3</sub>	C <sub>8</sub>
Octadecyl	Si-(CH <sub>2</sub> ) <sub>17</sub> -CH <sub>3</sub>	C <sub>18</sub>
Phenyl	Si-(CH <sub>2</sub> ) <sub>3</sub> -C <sub>6</sub> H <sub>5</sub>	C <sub>6</sub> H <sub>5</sub>
Cyanopropyl	Si-(CH <sub>2</sub> ) <sub>3</sub> -CN	CN
Aminopropyl	Si-(CH <sub>2</sub> ) <sub>3</sub> -NH <sub>2</sub>	NH <sub>2</sub>
Diol	Si-(CH <sub>2</sub> ) <sub>3</sub> -OCH(OH)-CH <sub>2</sub> -OH	

## Mobile phase

The choice of mobile phase is based on the desired retention behaviour and the physiochemical properties of the analyte.

For normal-phase HPLC using unmodified stationary phase, lipophilic solvent should be employed. The presence of water in the mobile phase must be avoided as this will reduce the efficacy of the stationary phase. In reverse-phase HPLC aqueous mobile phases with and without organic modifiers, are used.

The mobile phase should be filtered through suitable membrane type filters with a porosity of 0.45 $\mu$ m to remove mechanical particles. The solvent may be delivered by the individual pumps or proportioning valves of the liquid chromatograph and mixed according to the desired proportion. Solvents are normally degassed by sparging with helium or by sonification before pumping to avoid the creation of gas bubbles in the detector cell.

If an ultraviolet detector is employed, the solvent used for the preparation of the mobile phase should be free of stabilizer and transparent at the wavelength of detection. Mobile phase may contain other components, e.g. a counter-ion for ion pair chromatography or a chiral selector for chiral chromatography using an achiral stationary phase.

### **Connecting tubing and fittings**

The potential efficiency of an analytical column may never be achieved because of the design limitations of injector and detector. The connection between injector/column, column/detector, and/or detector/detector may compromise the overall efficiency of the system and any fitting should be the “zero dead volume” (ZDV) type. It is recommended that minimum length of capillary tubing with a maximum internal diameter of 0.25 mm be used for these fittings to minimize band spreading.

### **Detectors**

Ultraviolet/visible (UV/vis) absorption spectrometers are the most commonly used detector for pharmaceutical analysis. In specific cases, fluorescence spectrophotometers, differential refractometer, electro chemical detector, light-scattering detectors, mass spectrophotometers, or other special detector may be used. Where an analyte possesses a chromophoric group that absorbs UV/vis radiation, the UV/vis detector is the most appropriate because of its sensitivity and stability. Such a detector is not suitable for detecting analytes with very weak chromophores.

Enhanced sensitivity may be activated in certain cases by using pre-column or post-column derivatization techniques.

### **Data collection devices**

Signal from the detector may be collected on chart recorder or electronic integrators that vary in complexity and in their ability to process, store, and reprocess chromatographic data. The data storage capacity of these devices is usually limited.



## 17. ASSAY OF PARACETAMOL BY HPLC

Paracetamol is a common analgesic and antipyretic drug that is used for the relief of fever, headaches, and other minor aches and pains. Paracetamol is chemically 4-hydroxyacetanilide is a centrally and peripherally acting non-opioid analgesic and antipyretic.

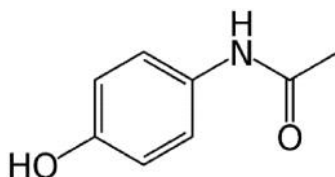

Paracetamol lacks many of the side effects of aspirin, unlike other common analgesics such as aspirin and ibuprofen, and has no anti-inflammatory properties, and so it is not a member of the class of drugs known as non-steroidal anti-inflammatory drugs or NSAIDs. Paracetamol does not irritate the lining of the stomach or affect blood coagulation as compared to aspirin. At normal therapeutic doses, paracetamol is metabolized very fast and completely by undergoing glucuronidation and sulphonation to inactive metabolites that are eliminated in the urine.

Paracetamol in formulations may be analyzed by high-performance liquid chromatography (HPLC).

HPLC is a chromatographic technique that can separate a mixture of compounds and is used in biochemistry and analytical chemistry to identify, quantify and purify the individual components of the mixture. HPLC typically utilizes different types of stationary phase (hydrophobic) saturated carbon chains, a pump that moves the mobile phase(s) and analyte through the column, and a detector that provides a characteristic retention time for the analyte. The detector may also provide other characteristic information (i.e. UV/Vis spectroscopic data for analyte if so equipped). Analyte retention



time varies depending on the strength of its interactions with the stationary phase, the ratio/composition of solvent(s) used, and the flow rate of the mobile phase.

With HPLC, a pump (rather than gravity) provides the higher pressure required to propel the mobile phase and analyte through the densely packed column. The increased density arises from smaller particle sizes. This allows for a better separation on columns of shorter length when compared to ordinary column chromatography. Linear absorbance is directly proportional to the increasing concentration. UV detectors are useful for analysis in HPLC systems. Above a certain concentration the linearity curves down, and loses direct proportionality due to molecular associations at higher concentrations. It must demonstrate linearity in validating response in an analytical procedure.

#### **Procedure:**

**Sample preparation:** Powder the sample equivalent to 50 mg of Paracetamol and suspend in 50 ml of methanol. Sonicate it for 10 min and dilute to 100 ml with methanol. Filter, dilute further and prepare 5, 7.5, 10, 12.5 and 15 mcg solution with mobile phase and prepare calibration graph, and determine the concentration of unknown sample.

#### **HPLC system:**

There are number of HPLC instruments are available in the market. Following system may be used for paracetamol analysis-

#### **Instrument:**

Waters 2487

#### **Column:**

Reverse Phase C-18 (5  $\mu$ m) column, 250 x 4.6 mm

### Chromatographic conditions:

1. Composition of mobile phase and its Ph: The mobile phase for paracetamol estimation is prepared by taking- Methanol : Water : *o*-Phosphoric acid (75 : 24.7 : 0.3 v/v).
2. Flow rate (Isocratic) : 1ml/min
3. Volume of injection : 20  $\mu$ l
4. Type of detector, detector mode and Wavelength (  $\lambda$  max): UV-264 nm
5. Retention time for Paracetamol; 2.15 min.

The following formula may be used for calculating % of paracetamol-

$$\% \text{ assay} = \frac{\text{Area of sample}}{\text{Area of standard}} \times \frac{\text{Wt. of Std}}{\text{Dilution Factor}} \times \frac{\text{Dilution Factor}}{\text{Wt. of sample}} \times \frac{\text{Avg. Wt. of 20 Tablet}}{\text{Label claim}} \times 100$$

## 18. TLC OF AMINO ACIDS

Thin layer chromatography (TLC) is an easy, convenient and inexpensive way to determine how many components are in a mixture and, in many instances, can be used to identify the components as well. In today's experiments, you will gain experience with both paper and thin layer chromatography, you will work with a variety of developing solvents, and you will use several different techniques to visualize the spots of a chromatogram.

Paper chromatography, which is used to separate amino acids, is a form of partition chromatography. Water, a component of the developing solvent, forms hydrogen bonds with the fibers of the paper and serves as the stationary phase. The organic liquids that are also present in the developing solvent serve as the mobile phase. The components of the mixture are drawn up the paper to different heights, depending on their solubility in the mobile phase. The compounds that are more soluble in the organic liquid remain dissolved in the mobile phase longer than those that are less soluble and thus travel further up the paper.

Proteins, large molecules found in all living organisms, serve a variety of functions in metabolism, such as catalysis, transport, storage, control of growth and immune protection. Amino acids are the building blocks of proteins. Every amino acid has an amino group, a carboxyl group and a distinctive side-chain. Nature uses twenty different amino acids to synthesize proteins.

Generally four amino acids (alanine, leucine, lysine, and valine) are separated in an UG/PG lab by paper chromatography are.

Amino acids are colorless compounds. In order to see the spots on the chromatogram, a solution of ninhydrin is applied to the paper. Ninhydrin reacts with the amino acid to produce a purple compound.

Silica gel serves as the stationary phase in the thin layer chromatography procedures. Finding a solvent or mixture of solvents that serves as an effective mobile phase is the most difficult part of TLC. Often several different combinations of solvents are tested before one is found that will separate the compounds of interest successfully. Different solvent systems affect the separation of the compounds.

The spots are illuminated when viewed under short-wave ultraviolet light. Some of the spots change color when exposed to iodine vapors.

### **Procedures:**

Obtain a sheet of 13 x 18.5 cm Whatman no. 1 chromatography paper. Hold it only on one of the long (18.5 cm) sides, which is considered the “top” of the sheet. The amino acids from student`s fingers will contaminate the paper and lead to erroneous results if it is touched on the “bottom”. Lay the sheet of chromatography paper on a piece of notebook paper, and draw a line *in pencil, not pen*, 1.5 cm above the bottom. Make small marks along the line using the dimensions. Use the small capillary tubes provided to make four spots, one of each amino acid (alanine, leucine, lysine and valine), along the pencil line. Follow the labels written at the top of the sheet. “unknown” sample contains one or more of these four amino acids. Spot this solution on the paper as well. For making every spot, touch the capillary to the surface of the paper *quickly and lightly* so that the spot is approximately 2-3 mm in diameter. Allow the spot to dry, then re-apply the solution at the exact same place, again touching the paper quickly and lightly. Allow the spot to dry, and repeat one more time. After all six solutions have been applied to the paper in this manner, allow the spots to dry for five minutes. Roll the paper into a cylinder with the spots on the outside, then staple it so that the edges do not overlap or touch.

Pour 50 mL of the amino acid developing solution into a 1000 mL beaker. The developing solvent is comprised of a four-to-one mixture of 1-butanol and glacial acetic acid that has been saturated with water. Position the cylinder inside the beaker with the

bottom edge immersed in the solvent. Make sure the paper does not touch the glass. Place a piece of aluminum foil over the mouth of the beaker. Allow the chromatogram to develop undisturbed for 60 to 75 minutes.

**Do not move the beaker while the chromatogram is developing!**

While removing the paper from the beaker, mark the solvent front with a pencil. Set the cylinder on notebook paper, and allow it to dry. When the chromatogram is completely dry, remove the staples, and hang it from the clips in the fume hood. Wearing gloves evenly coat the paper using the ninhydrin spray. Do not allow the paper to become dripping wet. Place the chromatogram in an oven set at 80° for about 5 minutes. Circle the spots with a pencil. Measure the distance from the origin to the center of each spot and the distance from the origin to the solvent front.

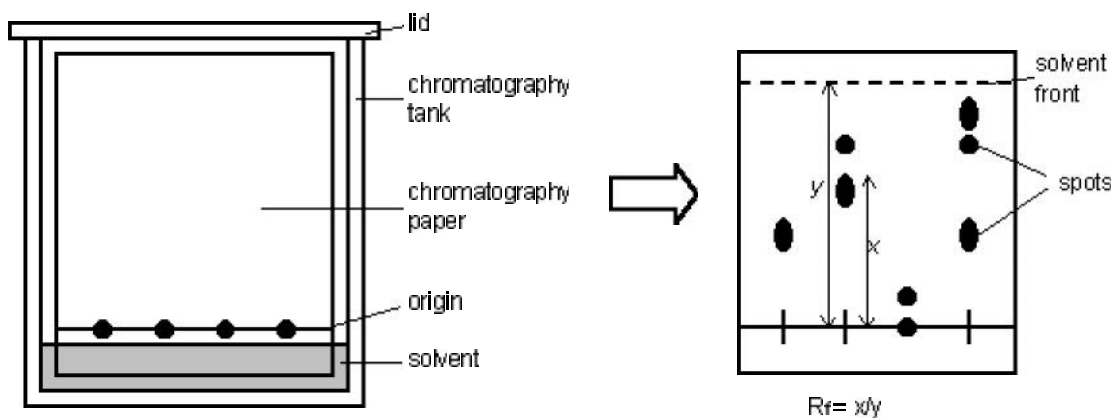

## 19. TLC OF FOOD DYE PIGMENTS

**Food coloring**, or color additive, is any dye, pigment or substance that imparts color when it is added to food or drink. They come in many forms consisting of liquids, powders, gels, and pastes. Food coloring is used both in commercial food production and in domestic cooking. Due to its safety and general availability, food coloring is also used in a variety of non-food applications including cosmetics, pharmaceuticals, home craft projects and medical devices

### Procedures:

Obtain two TLC plates with the dimensions of 5 cm x 6.7 cm. Draw a line *in pencil, not pen*, 1 cm from the bottom along the short (5 cm) side of each plate. Be careful not to disturb the silica gel as these lines are drawn!. Use the small capillary tube provided to spot four spots, one of each color, along the line drawn on each of the plates. When spotting a TLC plate, touch the capillary to the surface of the plate *quickly and lightly* so the spot is very small.

The spots will be highly colored since the food dye solutions are quite concentrated. Often times it is necessary to re-apply a dilute solution to the spot (allowing the spot to dry in between applications) until the spots are highly colored, however this will not be necessary in this case. Line a 250 mL beaker with a piece of filter paper. Place a small amount of the 3:1 isopropanol: concentrated ammonia developing solvent in the beaker. The liquid should cover the bottom of the beaker to a depth of about 0.5 cm; however, the level of the liquid *must* be below the line when the plate is placed in the jar (that is, less than 1 cm in depth). The filter paper lining will saturate the atmosphere within the beaker with solvent fumes. Fit a piece of aluminum foil over the mouth of the beaker. Place one of the plates that you have spotted in the beaker, cover it with the foil and allow the solvent front to move up the plate until it is approximately 1 cm from the top (one hour maximum).

**Do not disturb the beaker while the chromatogram is developing!**

Remove the plate and mark the solvent front with a pencil. Allow the plate to dry for a few minutes, then circle any visible spots with a pencil.

Into a filter paper lined 400 mL beaker, pour *either* pure isopropanol *or* 1:1 isopropanol: concentrated ammonia to a depth of about 0.5 cm. Develop the second plate in the same manner as the first using the chosen solvent. Mark the solvent front and circle the spots. Observe the chromatogram of the other solvent for the second plate.

Sketch diagrams of all three chromatograms in a notebook. Measure the distance from the origin to the center of each spot and the distance from the origin to the solvent front for each of the three chromatograms.

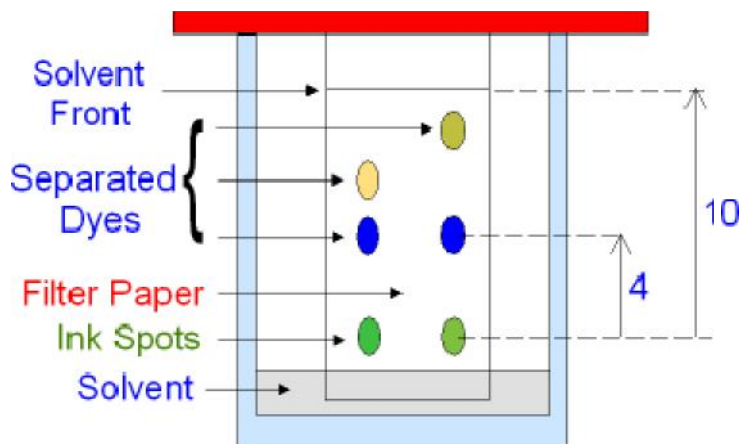

## **20. ANALYSIS OF A NON-PRESCRIPTION MEDICINE (OTC DRUG)**

Over-the-counter (OTC) drugs are medicines sold directly to a consumer without a prescription, from a healthcare professional, as compared to prescription drugs, which may be sold only to consumers possessing a valid prescription, e.g. Zantac, Acetoaminophen, Disprin, Ibuprofen, etc.

Students may get in analysis practical exam to analyze an OTC drug with the help of TLC. Generally they get commonly used OTC drugs like acetylsalicylic acid (aspirin), acetoaminophen (paracetamol), ibuprofen, caffeine and diphenhydramine.

### **Procedure:**

Obtain a silica gel TLC plate with the dimensions of 6 cm x 6.7 cm. Draw a line *in pencil* 1 cm from the bottom along the short (6 cm) side of the plate. Be careful not to disturb the silica gel as you draw the line! Use the small capillary tube provided to spot 4 spots, one of each active ingredient solution (acetylsalicylic acid, acetaminophen, caffeine and diphenhydramine), along the line. Leave room for a fifth spot for the unknown sample drug.

Spot your TLC plate with the supernatant from a mixture of this crushed tablet and methanol. When applying these solutions to the plate, touch the capillary to the surface of the silica gel *quickly and lightly* so the spot is very small. In each case, reapply the spot, allowing it to dry in between applications, two more times. Place a small amount of the ethyl acetate developing solvent in a 400 mL beaker. The liquid should cover the bottom of the beaker to a depth of about 0.5 cm. Line the beaker with a piece of filter paper to saturate the atmosphere within. Fit a piece of aluminum foil over the mouth of the beaker. Place the plate that you have spotted in the beaker, cover it with the foil, and allow the solvent front to move up the plate until it is approximately 1 cm from the top.



**Do not disturb the beaker while the chromatogram is developing!**

The solvent will travel up the silica gel plate very quickly and will reach the top in two to three minutes. Remove the plate and mark the solvent front with a pencil. Allow the plate to dry for a few minutes, then observe it under *short-wave* ultra-violet light. With a pencil, circle any spots that are illuminated.

Place the plate in an iodine chamber in such a way so that the silica gel surface is completely exposed to the iodine vapors and is not covered by other plates in the chamber. Leave it there for 5-10 minutes. After removing the plate from the chamber, record in the notebook whether or not any colored spots appeared as a result of exposure to the iodine vapors. If new spots appear, circle them with a pencil. Sketch a diagram of the chromatogram in the notebook. Measure the distance from the origin to the center of each spot and the distance from the origin to the solvent. The spot of the sample will match with any one of the four spots. This way unknown drug is identified.



## 21. PREPARATION OF SOME COMMON REAGENTS

The chemical reagents play an important role in the correctness of an experiment. If the composition of reagent is not correct, it often leads to errors in the observations and results. While preparing the chemistry reagents in a laboratory, correct proportion of chemicals and /or solvents as well as procedure is very crucial.

Safety is also very important, as Chemistry Labs are highly prone to accidents. While preparing reagents, one should be aware of correct handling, procedure, storage and safety hazards. One of the most common accidents which happen is while opening the bromine capsule to prepare bromine solution. However, with adequate knowledge and care, accidents can be avoided in the chemistry lab.

It is important to note that although most reagents can be prepared and stored, a few need to be freshly prepared. The commonly used formulas for calculation are:

1. Preparation of solutions using chemicals and dissolving them in appropriate solvents:

$$\text{Normality} = \frac{\text{Amount (g)} \times 1000}{\text{Equivalent wt} \times \text{Volume (ml)}}$$

2. Preparation of solutions/reagents of different strengths using concentrated solutions/reagents

$$N_1V_1 = N_2V_2$$

**Aluminon (qualitative test for aluminum).** Aluminon is a trade name for the ammonium salt of aurintricarboxylic acid. Dissolve 1 gm of the salt in 1 L of distilled water. Shake the solution well to insure thorough mixing.

**Bang's reagent.** Dissolve 100 gm of  $K_2CO_3$ , 66 gm of  $KCl$  and 160 gm of  $KHCO_3$  in the order given in about 700 mL of water at  $30^\circ C$ . Add 4.4 gm of  $CuSO_4$  and dilute to 1 L after the  $CO_2$  is evolved. This solution should be shaken only in such a manner as not to

allow entry of air. After 24 hours 300 mL are diluted to 1 L with saturated KCl solution, shaken gently and used after 24 hours; 50 mL is equivalent to 10 mg glucose.

**Barfoed's reagent.** See Cupric acetate.

**Benedict's solution (qualitative reagent for glucose).** With the aid of heat, dissolve 173 gm of sodium citrate and 100 gm of  $\text{Na}_2\text{CO}_3$  in 800 mL of water. Filter, if necessary, and dilute to 850 mL. Dissolve 17.3 gm of  $\text{CuSO}_4 \cdot 5\text{H}_2\text{O}$  in 100 mL of water. Pour the latter solution, with constant stirring, into the carbonate-citrate solution, and dilute to 1 L.

**Benzidine hydrochloride solution (for sulfite determination).**

Make a paste of 8 gm of benzidine hydrochloride ( $\text{C}_{12}\text{H}_8(\text{NH}_3)_2 \cdot 2\text{HCl}$ ) and 20 mL of water, add 20 mL of HCl (sp.gr. 1.12) and dilute to 1 L with water. Each mL of this solution is equivalent to 0.00357 gm of  $\text{H}_2\text{SO}_4$ .

**Bertrand's reagent.** Consists of the following solutions:

1. Dissolve 200 gm of Rochelle salt and 150 g of NaOH in sufficient water to make 1 L of solution.
2. Dissolve 40 gm of  $\text{CuSO}_4$  in enough water to make 1 L of solution.
3. Dissolve 50 gm of  $\text{Fe}_2(\text{SO}_4)_3$  and 200 gm of  $\text{H}_2\text{SO}_4$  (sp. gr. 1.84) in sufficient water to make 1 L of solution.
4. Dissolve 5 gm of  $\text{KMnO}_4$  in sufficient water to make 1 L of solution.

**Bial's reagent (for pentose).** Dissolve 1 gm of orcinol (5-methyl-1,3-benzenediol) in 500 mL of 30% HCl to which 30 drops of a 10% solution of  $\text{FeCl}_3$  has been added.

**Boutron — Boudet soap solution:**

1. Dissolve 100 gm of pure castile soap in about 2.5 L of 56% ethanol.
2. Dissolve 0.59 gm of  $\text{Ba}(\text{NO}_3)_2$  in 1 L of water.

Adjust the castile soap solution so that 2.4 mL of it will give a permanent lather with 40 mL of solution (b). When adjusted, 2.4 mL of soap solution is equivalent to 220 parts per million of hardness (as  $\text{CaCO}_3$ ) for a 40 mL sample. See also Soap solution.

**Brucke's reagent (protein precipitation).** See Potassium iodidemercuric iodide.

**Clarke's soap solution (estimation of hardness in water).**

1. Dissolve 100 gm of pure powdered castile soap in 1 L of 80% ethanol and allow to stand overnight.
2. Prepare a solution of  $\text{CaCl}_2$  by dissolving 0.5 gm of  $\text{CaCO}_3$  in HCl (sp. gr. 1.19), neutralize with  $\text{NH}_4\text{OH}$  and make slightly alkaline to litmus, and dilute to 500 mL. One mL is equivalent to 1 mg of  $\text{CaCO}_3$ . Titrate (1) against (2) and dilute (1) with 80% ethanol until 1 mL of the resulting solution is equivalent to 1 mL of (2) after making allowance for the lather factor (the amount of standard soap solution required to produce a permanent lather in 50 mL of distilled water). One mL of the adjusted solution after subtracting the lather factor is equivalent to 1 mg of  $\text{CaCO}_3$ . See also Soap solution.

**Cobalticyanide paper (Rinnmann's test for Zn).** Dissolve 4 gm of  $\text{K}_3\text{Co}(\text{CN})_6$  and 1 gm of  $\text{KClO}_3$  in 100 mL of water. Soak filter paper in solution and dry at  $100^\circ\text{C}$ . Apply drop of zinc solution and burn in an evaporating dish. A green disk is obtained if zinc is present.

**Cochineal.** Extract 1 gm of cochineal for 4 days with 20 mL of alcohol and 60 mL of distilled water. Filter.

**Congo red.** Dissolve 0.5 gm of Congo red in 90 mL of distilled water and 10 mL of alcohol.

**Cupferron (Baudisch's reagent for iron analysis).** Dissolve 6 gm of the ammonium salt of *N*-hydroxy-*N*-nitrosoaniline (cupferron) in 100 mL of  $\text{H}_2\text{O}$ . Reagent good for 1 week only and must be kept in the dark.

**Cupric acetate (Barfoed's reagent).** Dissolve 66 gm of cupric acetate and 10 mL of glacial acetic acid in water and dilute to 1 L.

**Cupric oxide, ammoniacal; Schweitzer's reagent (dissolves cotton, linen, and silk, but not wool).**

1. Dissolve 5 gm of cupric sulfate in 100 mL of boiling water, and add sodium hydroxide until precipitation is complete. Wash the precipitate well, and dissolve it in a minimum quantity of ammonium hydroxide.
2. Bubble a slow stream of air through 300 mL of strong ammonium hydroxide containing 50 gm of fine copper turnings. Continue for 1 hour.

**Cupric sulfate in glycerin-potassium hydroxide (reagent for silk).** Dissolve 10 gm of cupric sulfate,  $\text{CuSO}_4 \cdot 5\text{H}_2\text{O}$ , in 100 mL of water and add 5 gm of glycerol. Add KOH solution slowly until a deep blue solution is obtained.

**Cupron (precipitates copper).** Dissolve 5 g of benzoinoxime in 100 mL of 95% ethanol.

**Cuprous chloride, acidic (reagent for CO in gas analysis).**

1. Cover the bottom of a 2-L flask with a layer of cupric oxide about 0.5 inch deep, suspend a coil of copper wire so as to reach from the bottom to the top of the solution, and fill the flask with hydrochloric acid (sp. gr. 1.10). Shake occasionally. When the solution becomes nearly colorless, transfer to reagent bottles, which should also contain copper wire. The stock bottle may be refilled with dilute hydrochloric acid until either the cupric oxide or the copper wire is used up. Copper sulfate may be substituted for copper oxide in the above procedure.
2. Dissolve 340 gm of  $\text{CuCl}_2 \cdot 2\text{H}_2\text{O}$  in 600 mL of conc. HCl and reduce the cupric chloride by adding 190 mL of a saturated solution of stannous chloride or until the solution is colorless. The stannous chloride is prepared by treating 300 gm of metallic tin in a 500 mL flask with conc. HCl until no more tin goes into solution.

3. (Winkler method). Add a mixture of 86 gm of CuO and 17gm of finely divided metallic Cu, made by the reduction of CuO with hydrogen, to a solution of HCl, made by diluting 650 mL of conc. HCl with 325 mL of water. After the mixture has been added slowly and with frequent stirring, a spiral of copper wire is suspended in the bottle, reaching all the way to the bottom. Shake occasionally, and when the solution becomes colorless, it is ready for use.

**Cuprous chloride, ammoniacal (reagent for CO in gas analysis).**

1. The acid solution of cuprous chloride as prepared above is neutralized with ammonium hydroxide until an ammonia odor persists. An excess of metallic copper must be kept in the solution.

2. Pour 800 mL of acidic cuprous chloride, prepared by the Winkler method, into about 4 L of water. Transfer the precipitate to a 250 mL graduate. After several hours, siphon off the liquid above the 50 mL mark and refill with 7.5% NH<sub>4</sub>OH solution which may be prepared by diluting 50 mL of conc. NH<sub>4</sub>OH with 150 mL of water. The solution is well shaken and allowed to stand for several hours. It should have a faint odor of ammonia.

**Dichlorofluorescein indicator.** Dissolve 1 gm in 1 L of 70% alcohol or 1 gm of the sodium salt in 1 L of water.

**Dimethylglyoxime, 0.01 N.** Dissolve 0.6 gm of dimethylglyoxime (2,3-butanedione oxime) in 500 mL of 95% ethanol. This is an especially sensitive test for nickel, a very definite crimson color being produced

**Diphenylamine (reagent for rayon).** Dissolve 0.2 gm in 100 mL of concentrated sulfuric acid.

**Diphenylamine sulfonate (for titration of iron with K<sub>2</sub>Cr<sub>2</sub>O<sub>7</sub>).** Dissolve 0.32 gm of the barium salt of diphenylamine sulfonic acid in 100 mL of water, add 0.5 gm of sodium sulfate and filter off the precipitate of BaSO<sub>4</sub>.

**Diphenylcarbazide.** Dissolve 0.2 gm of diphenylcarbazide in 10 mL of glacial acetic acid and dilute to 100 mL with 95% ethanol.

**Esbach's reagent (estimation of protein).** To a water solution of 10 gm of picric acid and 20 gm of citric acid, add sufficient water to make 1 L of solution.

**Eschka's compound.** Two parts of calcined ("light") magnesia are thoroughly mixed with 1 part of anhydrous sodium carbonate.

**Fehling's solution (reagent for reducing sugars.)**

1. Copper sulfate solution. Dissolve 34.66 gm of  $\text{CuSO}_4 \cdot 5\text{H}_2\text{O}$  in water and dilute to 500 mL.

2. Alkaline tartrate solution. Dissolve 173 gm of potassium sodium tartrate (Rochelle salt,  $\text{KNaC}_4\text{H}_4\text{O}_6 \cdot 4\text{H}_2\text{O}$ ) and 50 gm of NaOH in water and dilute when cold to 500 mL. Mix equal volumes of the two solutions at the time of using.

**Ferric-alum indicator.** Dissolve 140 gm of ferric ammonium sulfate crystals in 400 mL of hot water. When cool, filter, and make up to a volume of 500 mL with dilute nitric acid.

**Folin's mixture (for uric acid).** To 650 mL of water add 500 gm of  $(\text{NH}_4)_2\text{SO}_4$ , 5 gm of uranium acetate, and 6 gm of glacial acetic acid. Dilute to 1 L.

**Formaldehyde — sulfuric acid (Marquis' reagent for alkaloids).** Add 10 mL of formaldehyde solution to 50 mL of sulfuric acid.

**Froehde's reagent.** See Sulfomolybdic acid.

**Fuchsin (reagent for linen).** Dissolve 1 gm of fuchsin in 100 mL of alcohol.

**Fuchsin — sulfurous acid (Schiff's reagent for aldehydes).** Dissolve 0.5 gm of fuchsin and 9 gm of sodium bisulfite in 500 mL of water, and add 10 mL of HCl. Keep in well-stoppered bottles and protect from light.

**Gunzberg's reagent (detection of HCl in gastric juice).** Prepare as needed a solution containing 4 gm of phloroglucinol (1,3,5-benzenetriol) and 2 gm of vanillin in 100 mL of absolute ethanol.

**Hager's reagent.** See Picric acid.

**Hanus solution (for iodine number).** Dissolve 13.2 gm of resublimed iodine in 1 L of glacial acetic acid which will pass the dichromate test for reducible matter. Add sufficient bromine to double the halogen content, determined by titration (3 mL is about the proper amount). The iodine may be dissolved by the aid of heat, but the solution should be cold when the bromine is added.

**Iodine (Tincture of Iodine).** To 50 mL of water add 70 gm of I<sub>2</sub> and 50 gm of KI. Dilute to 1 L with alcohol.

**Iodo-potassium iodide (Wagner's reagent for alkaloids).** Dissolve 2 gm of iodine and 6 gm of KI in 100 mL of water.

**Litmus (indicator).** Extract litmus powder three times with boiling alcohol, each treatment consuming an hour. Reject the alcoholic extract. Treat residue with an equal weight of cold water and filter; then exhaust with five times its weight of boiling water, cool and filter. Combine the aqueous extracts.

**Magnesia mixture (reagent for phosphates and arsenates).** Dissolve 55 gm of magnesium chloride and 105 gm of ammonium chloride in water, barely acidify with hydrochloric acid, and dilute to 1 L. The ammonium hydroxide may be omitted until just



previous to use. The reagent, if completely mixed and stored for any period of time, becomes turbid.

**Magnesium uranyl acetate.** Dissolve 100 gm of  $\text{UO}_2(\text{C}_2\text{H}_3\text{O}_2)_2 \cdot 2\text{H}_2\text{O}$  in 60 mL of glacial acetic acid and dilute to 500 mL. Dissolve 330 gm of  $\text{Mg}(\text{C}_2\text{H}_3\text{O}_2)_2 \cdot 4\text{H}_2\text{O}$  in 60 mL of glacial acetic acid and dilute to 200 mL. Heat solutions to the boiling point until clear, pour the magnesium solution into the uranyl solution, cool and dilute to 1 L. Let stand over night and filter if necessary.

**Marme's reagent.** See Potassium-cadmium iodide.

**Marquis' reagent.** See Formaldehyde-sulfuric acid.

**Mayer's reagent (white precipitate with most alkaloids in slightly acid solutions).**

Dissolve 1.358 gm of  $\text{HgCl}_2$  in 60 mL of water and pour into a solution of 5 gm of KI in 10 mL of  $\text{H}_2\text{O}$ . Add sufficient water to make 100 mL.

**Methyl orange indicator.** Dissolve 1 gm of methyl orange in 1 L of water. Filter, if necessary.

**Methyl orange, modified.** Dissolve 2 gm of methyl orange and 2.8 gm of xylene cyanole in 1 L of 50% alcohol.

**Methyl red indicator.** Dissolve 1 gm of methyl red in 600 mL of alcohol and dilute with 400 mL of water.

**Methyl red, modified.** Dissolve 0.50 gm of methyl red and 1.25 gm of xylene cyanole in 1 L of 90% alcohol. Or, dissolve 1.25 gm of methyl red and 0.825 gm of methylene blue in 1 L of 90% alcohol.

**Millon's reagent (for albumins and phenols).** Dissolve 1 part of mercury in 1 part of cold fuming nitric acid. Dilute with twice the volume of water and decant the clear solution after several hours.

**Molisch's reagent.** See 1-Naphthol.

**1-Naphthol (Molisch's reagent for wool).** Dissolve 15 gm of 1-naphthol in 100 mL of alcohol or chloroform.

**Nessler's reagent (for ammonia).** Dissolve 50 gm of KI in the smallest possible quantity of cold water (50 mL). Add a saturated solution of mercuric chloride (about 22 gm in 350 mL of water will be needed) until an excess is indicated by the formation of a precipitate. Then add 200 mL of 5 N NaOH and dilute to 1 L. Let settle, and draw off the clear liquid.

**Nickel oxide, ammoniacal (reagent for silk).** Dissolve 5 gm of nickel sulfate in 100 mL of water, and add sodium hydroxide solution until nickel hydroxide is completely precipitated. Wash the precipitate well and dissolve in 25 mL of concentrated ammonium hydroxide and 25 mL of water.

**Nitron (detection of nitrate radical).** Dissolve 10 gm of nitron (1,4-diphenyl-3-(phenylamino)-1,2,4-triazolium hydroxide) in 5 mL of glacial acetic acid and 95 mL of water. The solution may be filtered with slight suction through an alundum crucible and kept in a dark bottle.

**1-Nitroso-2-naphthol.** Make a saturated solution in 50% acetic acid (1 part of glacial acetic acid with 1 part of water).

**Nylander's solution (carbohydrates).** Dissolve 20 gm of bismuth subnitrate and 40 gm of Rochelle salt in 1 L of 8% NaOH solution. Cool and filter.

**Obermayer's reagent (for indoxyl in urine).** Dissolve 4 gm of  $\text{FeCl}_3$  in 1 L of HCl (sp. gr. 1.19).

**Oxine.** Dissolve 14 gm of 8-hydroxyquinoline in 30 mL of glacial acetic acid. Warm slightly, if necessary. Dilute to 1 L.

**Oxygen absorbent.** Dissolve 300 gm of ammonium chloride in 1 L of water and add 1 L of concentrated ammonium hydroxide solution. Shake the solution thoroughly. For use as an oxygen absorbent, a bottle half full of copper turnings is filled nearly full with the  $\text{NH}_4\text{Cl-NH}_4\text{OH}$  solution and the gas passed through.

**Pasteur's salt solution.** To 1 L of distilled water add 2.5 gm of potassium phosphate, 0.25 gm of calcium phosphate, 0.25 gm of magnesium sulfate, and 12.00 gm of ammonium tartrate.

**Pavy's solution (glucose reagent).** To 120 mL of Fehling's solution, add 300 mL of  $\text{NH}_4\text{OH}$  (sp. gr. 0.88) and dilute to 1 L with water.

**Phenanthroline ferrous ion indicator.** Dissolve 1.485 gm of 1,10-phenanthroline monohydrate in 100 mL of 0.025 M ferrous sulfate solution.

**Phenolphthalein.** Dissolve 1 gm of phenolphthalein in 50 mL of alcohol and add 50 mL of water.

**Phenolsulfonic acid (determination of nitrogen as nitrate).** Dissolve 25 gm of phenol in 150 mL of conc.  $\text{H}_2\text{SO}_4$ , add 75 mL of fuming  $\text{H}_2\text{SO}_4$  (15%  $\text{SO}_3$ ), stir well and heat for 2 hours at  $100^\circ\text{C}$ .

**Phloroglucinol solution (pentosans).** Make a 3% phloroglucinol (1,3,5-benzenetriol) solution in alcohol. Keep in a dark bottle.

**Phosphomolybdic acid (Sonnenschein's reagent for alkaloids).**

1. Prepare ammonium phosphomolybdate and after washing with water, boil with nitric acid and expel  $\text{NH}_3$ ; evaporate to dryness and dissolve in 2 M nitric acid.
2. Dissolve ammonium molybdate in  $\text{HNO}_3$  and treat with phosphoric acid. Filter, wash the precipitate, and boil with aqua regia until the ammonium salt is decomposed. Evaporate to dryness. The residue dissolved in 10%  $\text{HNO}_3$  constitutes Sonnenschein's reagent.

**Phosphoric acid — sulfuric acid mixture.** Dilute 150 mL of conc.  $\text{H}_2\text{SO}_4$  and 100 mL of conc.  $\text{H}_3\text{PO}_4$  (85%) with water to a volume of 1 L.

**Phosphotungstic acid (Schibier's reagent for alkaloids).**

1. Dissolve 20 gm of sodium tungstate and 15 gm of sodium phosphate in 100 mL of water containing a little nitric acid.
2. The reagent is a 10% solution of phosphotungstic acid in water. The phosphotungstic acid is prepared by evaporating a mixture of 10 gm of sodium tungstate dissolved in 5 gm of phosphoric acid (sp. gr. 1.13) and enough boiling water to effect solution. Crystals of phosphotungstic acid separate.

**Picric acid (Hager's reagent for alkaloids, wool and silk).** Dissolve 1 g of picric acid in 100 mL of water.

**Potassium antimonate (reagent for sodium).** Boil 22 gm of potassium antimonate with 1 L of water until nearly all of the salt has dissolved, cool quickly, and add 35 mL of 10% potassium hydroxide. Filter after standing overnight.

**Potassium-cadmium iodide (Marme's reagent for alkaloids).**

Add 2 gm of  $\text{CdI}_2$  to a boiling solution of 4 gm of KI in 12 mL of water, and then mix with 12 mL of saturated KI solution.

**Potassium hydroxide (for CO<sub>2</sub> absorption).** Dissolve 360 gm of KOH in water and dilute to 1 L.

**Potassium iodide—mercuric iodide (Brucke's reagent for proteins).**

Dissolve 50 gm of KI in 500 mL of water, and saturate with mercuric iodide (about 120 g). Dilute to 1 L.

**Potassium pyrogallate (for oxygen absorption).** For mixtures of gases containing less than 28% oxygen, add 100 mL of KOH solution (50 g of KOH to 100 mL of water) to 5 gm of pyrogallol. For mixtures containing more than 28% oxygen the KOH solution should contain 120 gm of KOH to 100 mL of water.

**Pyrogallol, alkaline.**

1. Dissolve 75 g of pyrogallic acid in 75 mL of water.
  2. Dissolve 500 gm of KOH in 250 mL of water. When cool, adjust until sp. gr. is 1.55.
- For use, add 270 mL of solution (2) to 30 mL of solution (1).

**Rosolic acid (indicator).** Dissolve 1 gm of rosolic acid in 10 mL of alcohol and add 100 mL of water.

**Scheibler's reagent.** See Phosphotungstic acid.

**Schiff's reagent.** See Fuchsin-sulfurous acid.

**Schweitzer's reagent.** See Cupric oxide, ammoniacal.

**Soap solution (reagent for hardness in water).** Dissolve 100 gm of dry castile soap in 1 L of 80% alcohol (5 parts alcohol to 1 part water). Allow to stand several days and dilute with 70% to 80% alcohol until 6.4 mL produces a permanent lather with 20 mL of standard calcium solution. The latter solution is made by dissolving 0.2 gm of CaCO<sub>3</sub> in a small amount of dilute HCl, evaporating to dryness and making up to 1 L.

**Sodium bismuthate (oxidation of manganese).** Heat 20 parts of NaOH nearly to redness in an iron or nickel crucible and add slowly 10 parts of basic bismuth nitrate which has been previously dried. Add 2 parts of sodium peroxide, and pour the brownish-yellow fused mass onto an iron plate to cool. When cold, break up in a mortar, extract with water, and collect on an asbestos filter.

**Sodium hydroxide (for CO<sub>2</sub> absorption).** Dissolve 330 gm of NaOH in water and dilute to 1 L.

**Sodium nitroprusside (reagent for hydrogen sulfide and wool).** Use a freshly prepared solution of 1 gm of sodium nitroferricyanide in 10 mL of water.

**Sodium oxalate (primary standard).** Dissolve 30 gm of the commercial salt in 1 L of water, make slightly alkaline with sodium hydroxide, and let stand until perfectly clear. Filter and evaporate the filtrate to 100 mL. Cool and filter. Pulverize the residue and wash it several times with small volumes of water. The procedure is repeated until the mother liquor is free from sulfate and is neutral to phenolphthalein.

**Sodium plumbite (reagent for wool).** Dissolve 5 gm of sodium hydroxide in 100 mL of water. Add 5 gm of litharge (PbO) and boil until dissolved.

**Sodium polysulfide.** Dissolve 480 gm of Na<sub>2</sub>S·9H<sub>2</sub>O in 500 mL of water, add 40 gm of NaOH and 18 gm of sulfur. Stir thoroughly and dilute to 1 L with water.

**Sonnenschein's reagent.** See Phosphomolybdic acid.

#### **Starch solution.**

1. Make a paste with 2 gm of soluble starch and 0.01 gm of HgI<sub>2</sub> with a small amount of water. Add the mixture slowly to 1 L of boiling water and boil for a few minutes. Keep in

a glass stoppered bottle. If other than soluble starch is used, the solution will not clear on boiling; it should be allowed to stand and the clear liquid decanted.

2. A solution of starch which keeps indefinitely is made as follows: Mix 500 mL of saturated NaCl solution (filtered), 80 mL of glacial acetic acid, 20 mL of water and 3 gm of starch. Bring slowly to a boil and boil for 2 minutes.

3. Make a paste with 1 gm of soluble starch and 5 mg of  $\text{HgI}_2$ , using as little cold water as possible. Then pour about 200 mL of boiling water on the paste and stir immediately. This will give a clear solution if the paste is prepared correctly and the water actually boiling. Cool and add 4 gm of KI. Starch solution decomposes on standing due to bacterial action, but this solution will keep well if stored under a layer of toluene.

**Stoke's reagent.** Dissolve 30 g of  $\text{FeSO}_4$  and 20 gm of tartaric acid in water and dilute to 1 L. Just before using, add concentrated  $\text{NH}_4\text{OH}$  until the precipitate first formed is redissolved.

**Sulfanilic acid (reagent for nitrites).** Dissolve 0.5 gm of sulfanilic acid in a mixture of 15 mL of glacial acetic acid and 135 mL of recently boiled water.

**Sulfomolybdic acid (Froehde's reagent for alkaloids and glucosides).** Dissolve 10 gm of molybdic acid or sodium molybdate in 100 mL of conc.  $\text{H}_2\text{SO}_4$ .

**Tannic acid (reagent for albumin, alkaloids, and gelatin).** Dissolve 10 gm of tannic acid in 10 mL of alcohol and dilute with water to 100 mL.

**Titration mixture (residual chlorine in water analysis).** Prepare 1 L of dilute HCl (100 mL of HCl (sp. gr. 1.19) in sufficient water to make 1 L). Dissolve 1 g of *o*-tolidine in 100 mL of the dilute HCl and dilute to 1 L with dilute HCl solution.

**Trinitrophenol solution.** See Picric acid.

**Turmeric tincture (reagent for borates).** Digest ground turmeric root with several quantities of water which are discarded. Dry the residue and digest it several days with six times its weight of alcohol. Filter.

**Uffelmann's reagent (turns yellow in presence of lactic acid).** To a 2% solution of pure phenol in water, add a water solution of  $\text{FeCl}_3$  until the phenol solution becomes violet in color.

**Wagner's reagent.** See Iodo-potassium iodide.

**Wagner's solution (used in phosphate rock analysis to prevent precipitation of iron and aluminum).** Dissolve 25 gm of citric acid and 1 gm of salicylic acid in water and dilute to 1 L. Use 50 mL of the reagent.

**Wij's iodine monochloride solution (for iodine number).** Dissolve 13 gm of resublimed iodine in 1 L of glacial acetic acid which will pass the dichromate test for reducible matter. Set aside 25 mL of this solution. Pass into the remainder of the solution dry chlorine gas [dried and washed by passing through  $\text{H}_2\text{SO}_4$  (sp. gr. 1.84)] until the characteristic color of free iodine has been discharged. Now add the iodine solution which was reserved, until all free chlorine has been destroyed. A slight excess of iodine does little or no harm, but an excess of chlorine must be avoided. Preserve in well stoppered, amber colored bottles. Avoid use of solutions which have been prepared for more than 30 days.

**Wij's special solution (for iodine number).** To 200 mL of glacial acetic acid that will pass the dichromate test for reducible matter, add 12 g of dichloramine T (*N,N*-dichloro-4-methylbenzenesulfonamide), and 16.6 gm of dry KI (in small quantities with continual shaking until all the KI has dissolved). Make up to 1 L with the same quality of acetic acid used above and preserve in a dark colored bottle.



**Zimmermann-Reinhardt reagent (determination of iron).** Dissolve 70 g of  $\text{MnSO}_4 \cdot 4\text{H}_2\text{O}$  in 500 mL of water, add 125 mL of conc.  $\text{H}_2\text{SO}_4$  and 125 mL of 85%  $\text{H}_3\text{PO}_4$ , and dilute to 1 L.

**Zinc amalgam.** Add about 10 gm of granulated zinc to 20 mL mercury, to produce a liquid amalgam on cooling, and heat to 150 °C with stirring until the zinc is dissolved.

**Zinc amalgated (Jones Reductor).** The zinc is amalgated by immersing it in a solution of mercuric chloride in hydrochloric acid. A quantity of 250 gm of 20 mesh zinc is covered with water in a 1 liter flask, and a solution of 11 gm of mercuric chloride in 100 mL of hydrochloric acid is poured into the flask. The system is slowly mixed and shaken for about 2 min. The solution is poured off, and the amalgam is washed thoroughly with hot tap water, then distilled water.

**Zinc chloride solution, basic (reagent for silk).** Dissolve 1000 g of zinc chloride in 850 mL of water, and add 40 g of zinc oxide. Heat until solution is complete.

**Zinc uranyl acetate (reagent for sodium).** Dissolve 10 g of  $\text{UO}_2(\text{C}_2\text{H}_3\text{O}_2)_2 \cdot 2\text{H}_2\text{O}$  in 6 g of 30% acetic acid with heat, if necessary, and dilute to 50 mL. Dissolve 30 g of  $\text{Zn}(\text{C}_2\text{H}_3\text{O}_2)_2 \cdot \text{H}_2\text{O}$  in 3 g of 30% acetic acid and dilute to 50 mL. Mix the two solutions, add 50 mg of NaCl, allow to stand overnight and filter.

## 22. REFERENCES

BANWELL COLIN and MC CASH ELAINE, *Fundamentals of Molecular Spectroscopy*, Mc Graw-Hill, 1994.

CAREY F.A. and SUNDBERG R.A., *Advanced Organic Chemistry*, 5<sup>th</sup> Ed, Springer, 2007.

DUXBURY G., *Infrared Vibration-Rotation Spectroscopy, From Free Radicals to the Infrared Sky*, Wiley, 1999.

HARGIS L.G., *Analytical Chemistry: Principles and Techniques*, 1988.

HOLLAND J. G. and S. D. TANNER, *Plasma Source Mass spectrometry- New Developments and Applications*, 1999.

IP 1996.

JACKSON K. W., *Electrothermal Atomization for Analytical Atomic Spectrometry*, 1999.

JENKINS R., *X-Ray Fluorescence Spectrometry - New Developments and Applications*, 1999.

KHOO S.B.(ed.), *Analytical Chemistry*, 1989.

KENNEDY J.H., *Analytical Chemistry: principles*, 2d ed., 1990.

KOLTHOFF I.M. and ELVING P.J., *Treatise on analytical chemistry*, 2d ed., vols.1-4, 1978-1984, vol.5, 1982, vol.6, 1988, vol.7, 1981, vol.8, pt.1, 1988, vol.12, 1983.

LINDON John C., *Encyclopedia of Spectroscopy and Spectrometry*, Academic Press, 1999.

RUBINSON K.A., *Chemical analysis*, 1987.

SKOOG D.A., WEST D.M and HOLLER F.J., *Fundamentals of Analytical Chemistry*, 6<sup>th</sup> ed., 1992.

VOGEL A.I., *Vogel's Textbook of Practical Organic Chemistry*, 5th Ed., Prentice Hall, USA, 1996

WILLIAMS P.A. and Dyer A., *Advances in Ion Exchange for Industry and Research*, 1999.

WINEFORDNER J.D., *Treatise on Analytical Chemistry*, 2nd ed., vol.13, 1993.